

XTEND



Description

The XTEND enables IQ networks running on the Trend current loop Lan, Ethernet, and LONWORKS® network to be integrated into a single network. It operates at the internetwork level, including the necessary support for WAN's. It also provides virtual CNCs that allow supervisory or tool software running in PCs connected to the Ethernet network to connect to the BMS system.

Operation on a LONWORKS network is achieved without the need for any LONWORKS network management.

Features

- Integration of IQ network on Trend current loop Lan, Ethernet and LONWORKS network.
- 10/100 BASE-T interface.
- Eight virtual CNCs for PC connection using Ethernet.
- Can span routers.
- Network alarms available in 10 languages.
- Flash memory retains configured data during power fail (no battery required).
- Integration of IQL controllers into Trend system.
- Connection to LONWORKS network with IqTool 2 using virtual CNC.
- DHCP Enabled.

Physical

Dimensions

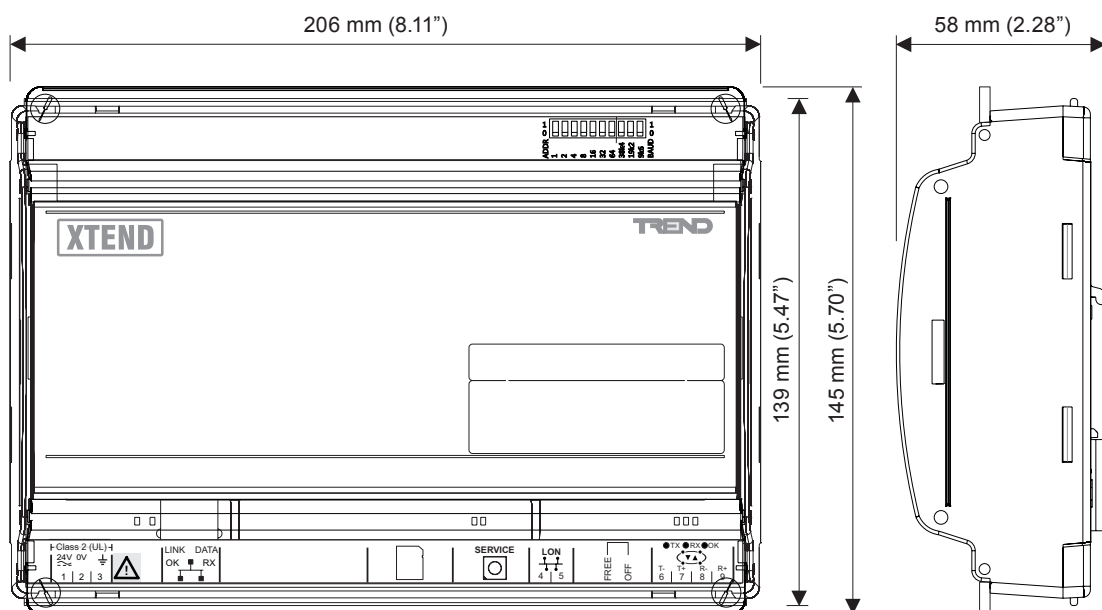

PHYSICAL (continued)

Features

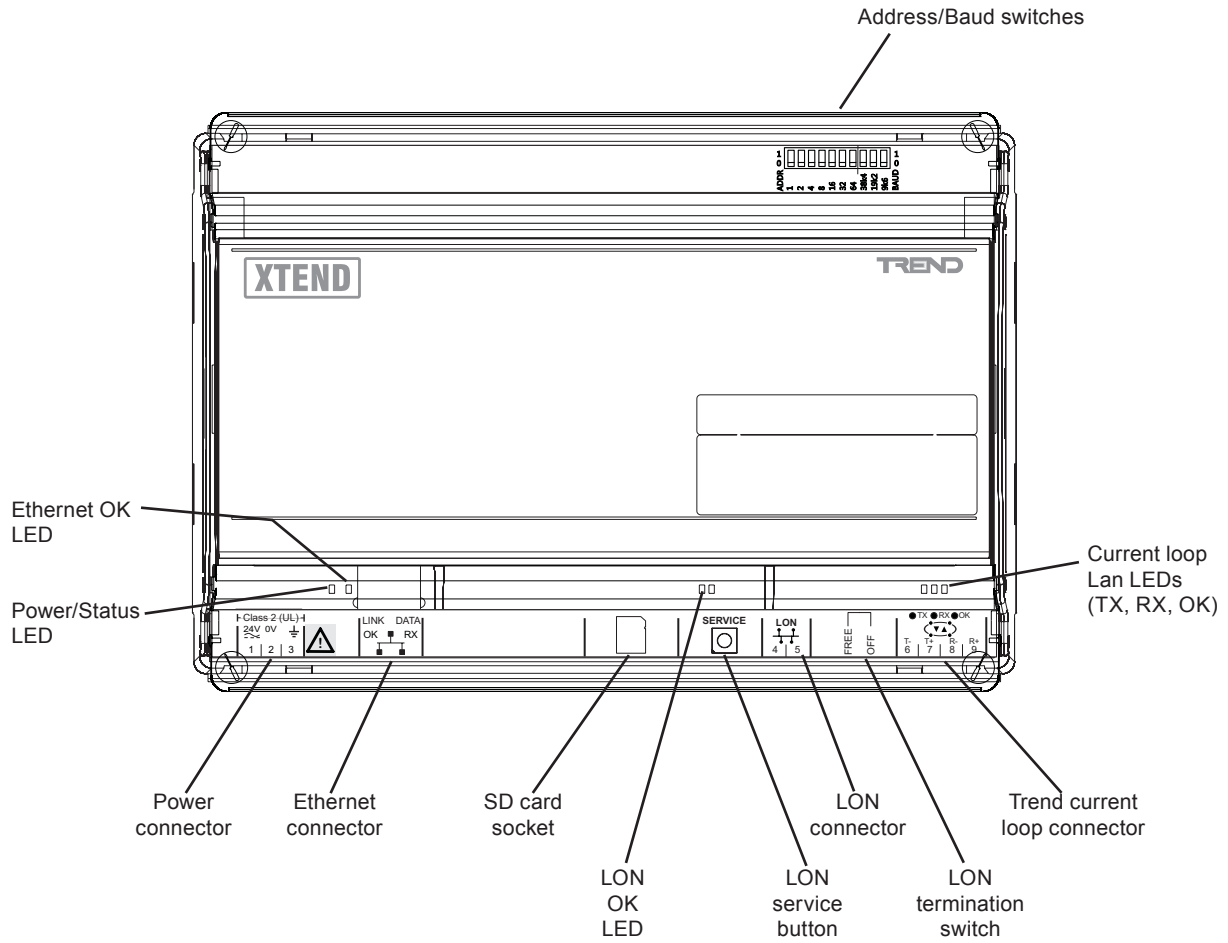

FUNCTIONALITY

The functionality of the XTEND can be split into system, hardware, and firmware sections:

SYSTEM

The XTEND enables different parts of an IQ network running over a Trend current loop, Ethernet, and LONWORKS networks, to form a single IQ network.

A typical system without XTEND is shown below:

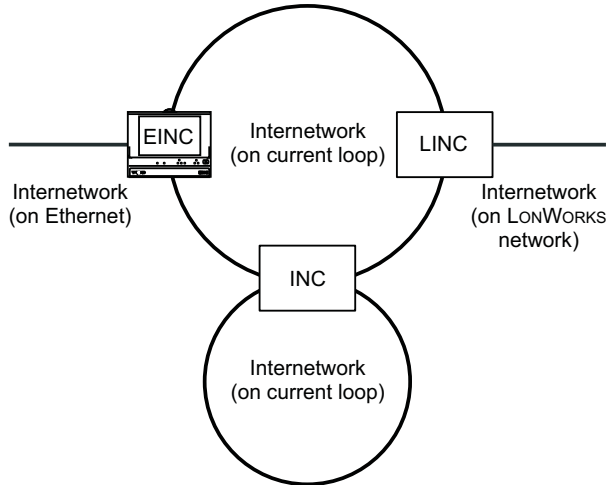

The equivalent system using XTEND would look like this:

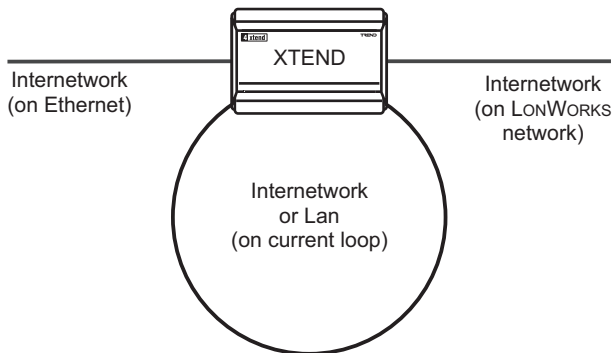

Note that the functions of the EINC, LINC, and INC are replaced by the XTEND.

The XTEND operates in one of two modes, depending on how the current loop network is configured:

INC mode which enables a Lan running on a current loop network to be joined with an internetwork running on an Ethernet network and an internetwork running on a LONWORKS bus.

Note that when operating in INC mode it is not possible to have another internetworking device (INC or another XTEND) on the Trend current loop.

Internetwork Extension mode which enables an internetwork running on a current loop network to be joined with an internetwork running on an Ethernet network and an internetwork running on a LONWORKS bus, to form a single IQ network.

The mode of operation is determined by the address set on the XTEND address switch. When set to a value less than 100 the current loop will operate in INC mode when set to a value greater than or equal to 100 the current loop will operate in Internetwork Extension mode.

Note that it is recommended that the LONWORKS network is not used where a high level of communication traffic is expected, e.g. joining internetworks or where there are many Trend devices on many Trend Lans being accessed across an internetwork routed through the LONWORKS network. An alternative topology should be used, such as an Ethernet internetwork.

INC Mode

Using the XTEND in INC mode enables a Lan running on a current loop network to be joined with an internetwork running on an Ethernet network and an internetwork running on a LONWORKS bus, as shown in the following example:

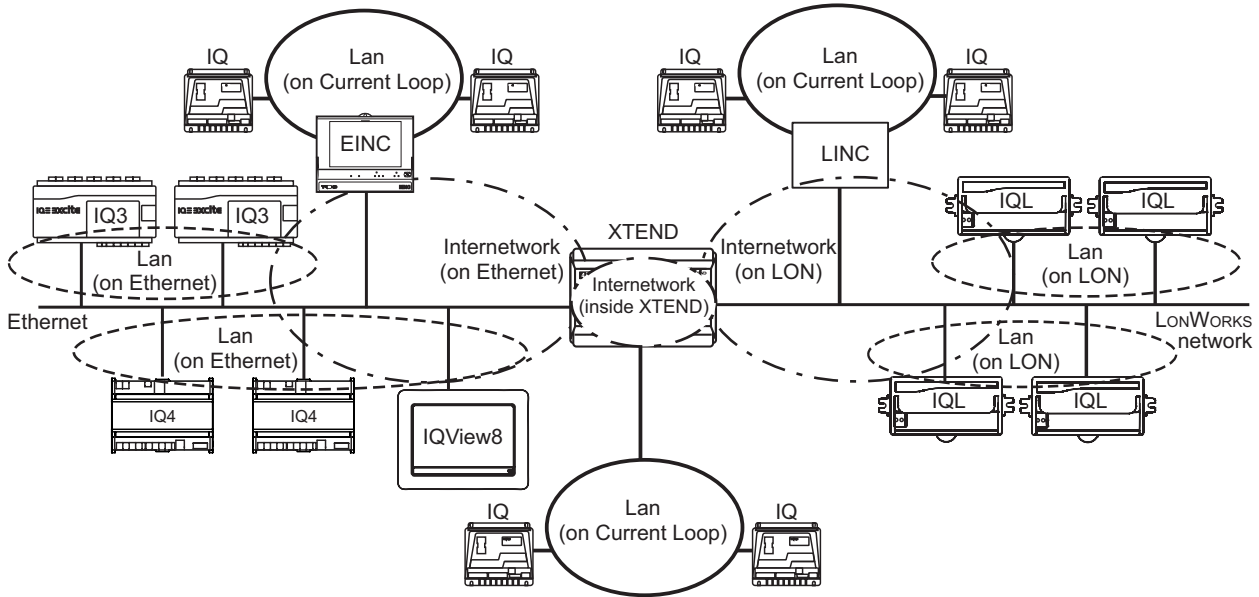

The diagram above shows an Ethernet network, LONWORKS network and Trend current loop joined by a XTEND to form a single IQ network. The XTEND builds a single internetwork which links together all seven Lans.

Note that when operating in this mode it is not possible to have another internetworking device (INC or another XTEND) on the Trend current loop.

The Lan number for the XTEND's Local Lan is defined by the address switch. This Lan will comprise:

- any devices physically connected to the XTEND current loop
- the XTEND virtual CNCs
- the XTEND INC (which always has address 126).

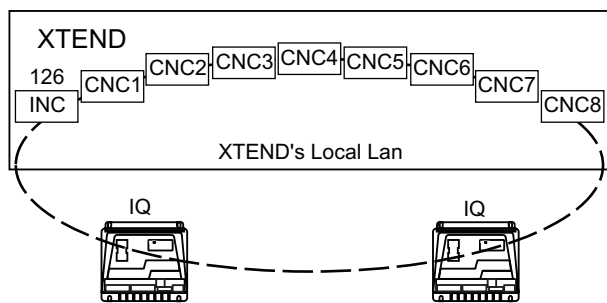

Internetwork Extension Mode

Using the XTEND in INC mode enables an internetwork running on a current loop network to be joined with an internetwork running on an Ethernet network and an internetwork running on a LONWORKS bus, as shown in the following example.

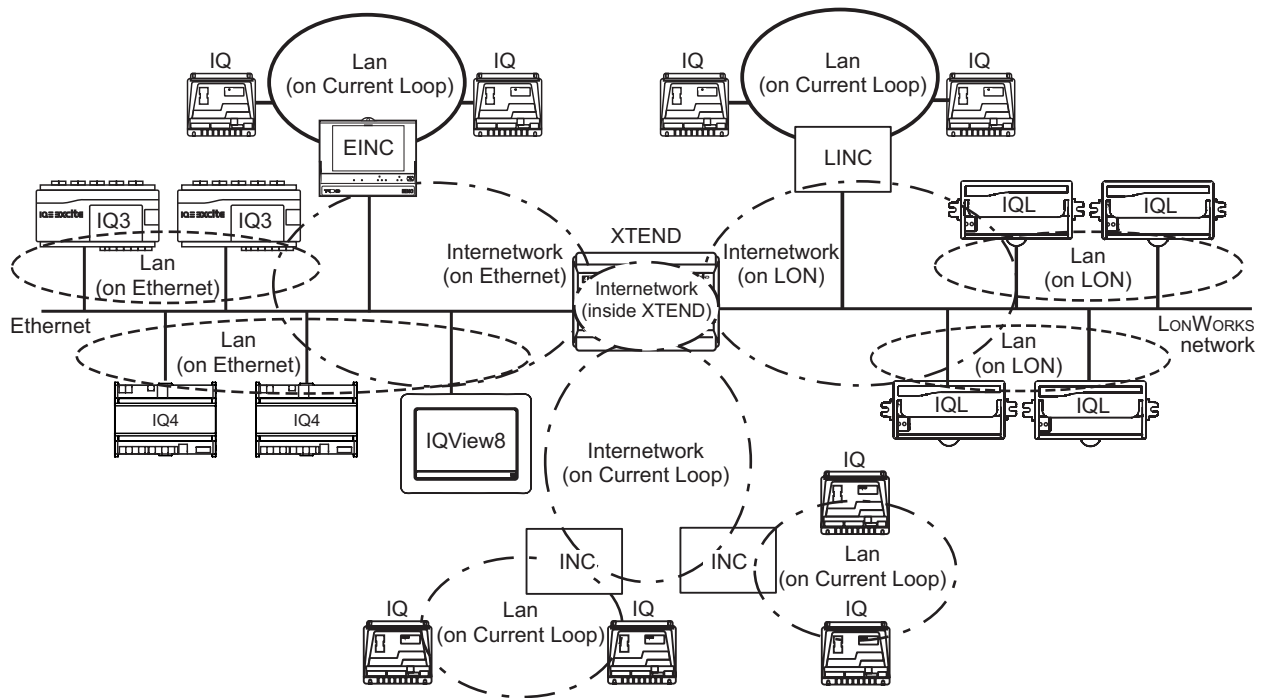

The diagram above shows an Ethernet network, LONWORKS network and Trend current loop joined by a XTEND to form a single IQ network. The XTEND builds a single internetwork which links together all eight Lans.

The Lan number for the XTEND's Local Lan is defined by the address switch. This Lan will comprise:

- the XTEND virtual CNCs
- the XTEND INC (which always has address 126).

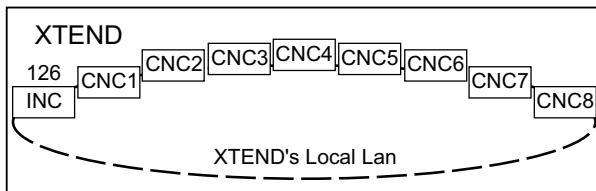

Note that only one internetwork device is allowed on a Lan therefore ensure that the XTEND's LAN number is not used by another INC type device.

Virtual CNCs

The XTEND's firmware incorporates eight virtual CNCs that enable a connection to be made over Ethernet between a PC running supervisor/tool software and the IQ network. They also enable alarms generated from IQs or other devices to be transmitted to a PC running 963. In order to do this each of the virtual CNCs can act in on of two modes:

- Supervisor mode
- Alarm mode

For a virtual CNC to operate, its CNC address must be set up using IPTool or in configuration mode. The virtual CNC is switched from a supervisor mode to alarm mode by setting up an alarm IP address or host name in the virtual CNC module. Once enabled, the virtual CNCs appear to be located on the XTEND's local Lan, and will respond to Lan mapping in this way.

Supervisor Mode

This enables the Ethernet network to be used as a connection between a PC running supervisory or tool software and the virtual CNC (rather than an RS232, device to CNC, interface). The supervisor connects to the CNC by using the XTEND's host name or IP address and the port address set up in the virtual CNC module, making a permanent connection to the virtual CNC. This enables the supervisor/tool to communicate with devices on the IQ network, and for those devices to communicate with it.

The 963 can make a connection to the virtual CNC when information is required, treating each connection as a separate site. However, temporary connections will not allow the virtual CNC to send alarms back to the supervisor; instead a virtual CNC in alarm mode must be used.

When IqTool 2 connects to a virtual CNC in supervisor mode IqTool 2 detects that the virtual CNC is capable of communications with devices on a LONWORKS network enabling IqTool 2 to connect to the LONWORKS network over an Ethernet network.

In the diagram below the supervisor/tool connects to the XTEND virtual CNC2 over Ethernet, and will have a Lan address of 24 and a network address of 24 on the IQ network.

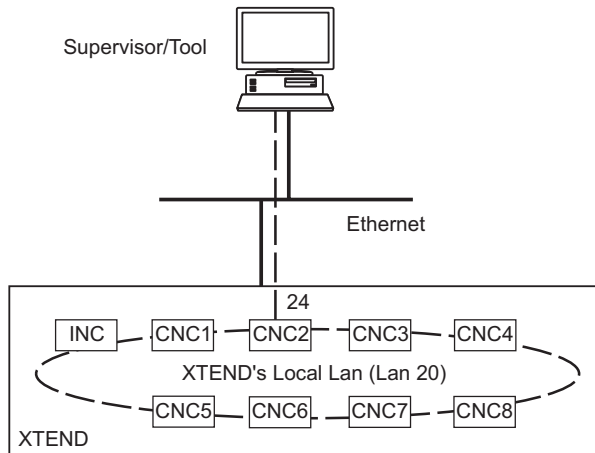

Alarm Mode

The Alarm mode of a virtual CNC enables alarms generated from IQs or other devices to be transmitted to a PC running 963 v3 or greater or 963 connected to the Ethernet where the connection to the virtual CNC is of a temporary nature. An IQ can send its alarms to the virtual CNC using normal Lan/device addressing, and the virtual CNC will forward the alarms to the PC using the Port Address and the Alarm host name/IP address, specified in the virtual CNC. The 963 listens for alarms on the specified port, and retrieves the site identities, Lan numbers, and device addresses of any alarms it receives so that it can process them further.

In the diagram below the 963 is able to connect to the site on which the XTEND is situated, using a temporary connection to virtual CNC1 which is in supervisor mode. Virtual CNC2 is operating in alarm mode and set to forward alarms it receives to the IP address of the 963.

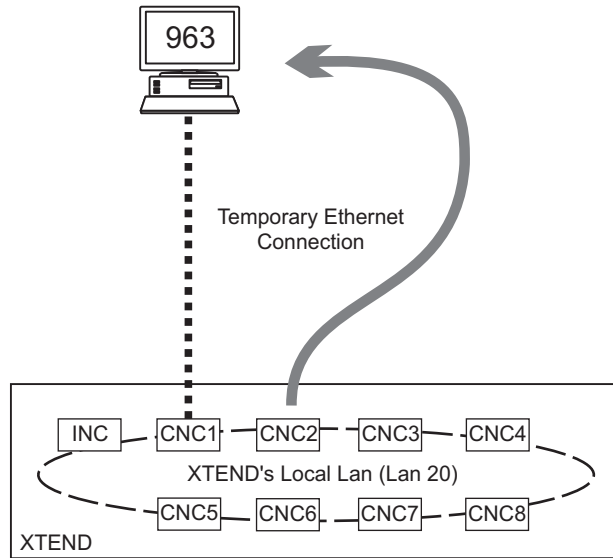

Building Internetworks On Ethernet

The XTEND will build an internetwork with other Trend devices that are connected to the Ethernet network. If there is more than one Trend device on the same segment of the Ethernet network (i.e. no routers between them) and they use the same UDP port they will automatically form a single internetwork as shown in the example below.

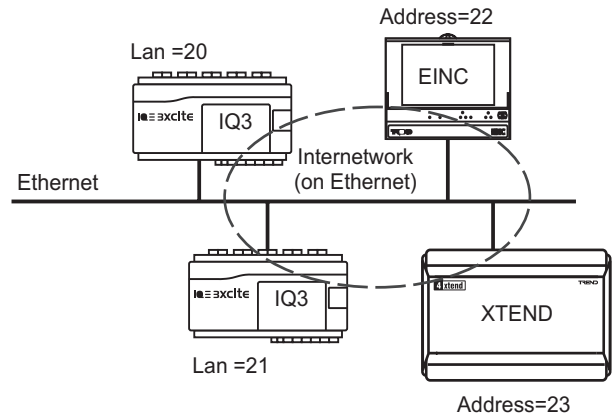

If any devices have formed Lans the device with the lowest IP address will assume INC functionality and will be included in the internetwork. In the diagram above the XTEND, IQ3 controllers and the EINC are on the same network segment and the IQ3 controllers have different Lan numbers. Therefore they form an internetwork consisting of Lan 20, Lan 21, Lan 22, and Lan 23.

When there are routers on the Ethernet network, and it is required for the internetwork to be built across routers, a Trend Ethernet device must be installed on either side of the router and be configured to span the routers.

In the example below, if none of the devices have their remote devices table setup they will be unable to build an internetwork across the router, and will construct two separate internetworks as shown. This is effectively two separate sites:

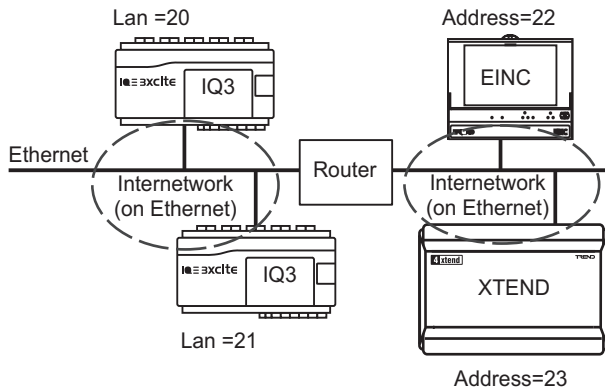

For the sites to combine, the remote devices table must be set up in each device on the system. The remote devices table must contain the details of two devices in the network from each other subnet and be set up in every device on the local subnet. For increased reliability, details of additional devices should also be set up. In the example below all the devices have had their remote devices table setup. This allows the two sites to combine to form one single site:

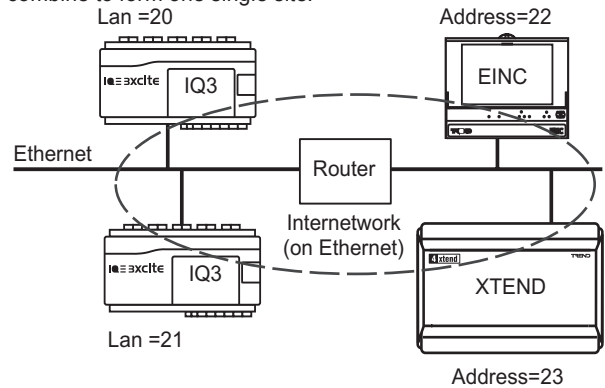

The setting up of the table in more than one device across routers is facilitated by the 'uPdatelist' configuration module. This enables the remote devices table from the XTEND to be copied to all the XTENDs and EINC in the table.

UDP Port

The UDP (User Datagram Protocol) port number defines the Ethernet port used by the XTEND to send messages to other Trend Ethernet devices. To construct an internetwork, the devices must be on the same subnet (unless set up to span routers), and must use the same UDP port. If the user is restricted to using one subnet, but wishes to have separate sites on that subnet (i.e. more than one internetwork), then he can set different UDP port numbers for the groups of Trend Ethernet devices in the different internetworks.

Building Internetworks on a LonWORKS network

The XTEND will build an internetwork with other Trend devices that are connected to the LonWORKS network. If there is more than one of these devices on the LonWORKS network they will automatically form a single internetwork as shown below:

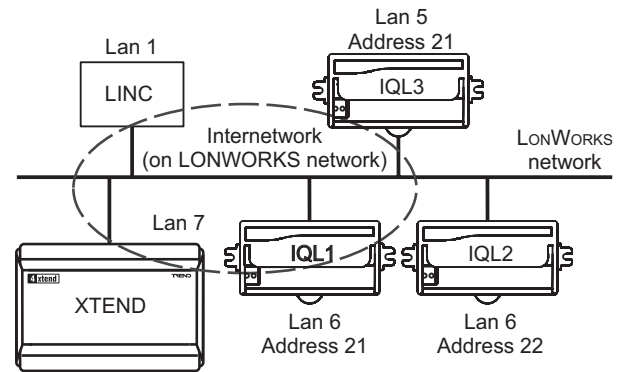

If IQLs have formed Lans the device with the lowest address will assume INC functionality and will be included in the internetwork. In the diagram above the XTEND, the IQL controllers, and LINC are on the same network segment. IQL 1 and 2 have the same Lan address and form a Lan. IQL3, and IQL1 have the lowest address on their Lans and assume INC functionality and will build an internetwork with the XTEND, and LINC consisting of Lan 1, Lan 5, Lan 6, and Lan 7.

Note that XTEND is not compatible with LONCs. The LONC must be bound on a LonWORKS network, and XTEND cannot be bound. An EINC and LINC must be used instead.

Rules for a Trend Network on a LonWORKS Network

The maximum number of nodes allowed on an FTT LonWORKS network segment (i.e. between routers) is 64 (including any router nodes). The recommended maximum number of nodes on a Lan is 40.

Connection to Network on a LonWORKS Network using a Virtual CNC

When IqITool 2 connects to a virtual CNC in supervisor mode IqITool 2 detects that the virtual CNC is capable of communications with devices on a LonWORKS network. This enables IqITool 2 to connect to the network on the LonWORKS network over an Ethernet network without the need for an LCI. If any of the XTEND's virtual CNCs are connected to by IqITool 2 the address modules vlci in use parameter is set to Yes. Only one virtual CNC can be connected in this way at a time.

Ethernet Addressing

The XTEND's Ethernet addressing information can be set up automatically (automatic addressing) or manually (manual addressing). The default mode of operation is automatic addressing enabling the XTEND to be easily set up.

Note that when setting up the Ethernet addressing ensure that there is only one subnet on a network segment.

Automatic Addressing

The XTEND is able to operate on an Ethernet system where the IP addressing information (IP address, subnet mask, default router, and WINS Server) are automatically allocated by a Dynamic Host Configuration Protocol (DHCP) server or the IP address is automatically negotiated with other devices. This means that the IP address is not fixed.

When in auto addressing mode the XTEND obtains IP addressing information from a DHCP server. If there is no DHCP server or the DHCP server fails the XTEND enters link/local mode where it auto-negotiates its IP address with other devices on its Ethernet segment. There may be some delay between DHCP server failure and the XTEND entering link/local mode as it will only prompt the DHCP server after its lease has expired, which may be a long time.

When in link/local mode IP addresses start at 169.254.0.0 with subnet mask of 255.255.0.0; ensuring all devices in link/local mode are on the same subnet, the default router, and WINS server address remain at their last settings. Any devices wanting to communicate with them using IP addressing must be on this subnet.

Fixing the XTEND's address on a DHCP controlled System: It is possible for the XTEND to operate in a DHCP regime with a fixed IP address by setting up the DHCP server so that it always gives the XTEND the same IP address. An alternative is to set the XTEND to use manual addressing and set its IP address outside the range of the DHCP server.

Connecting to an automatically addressed XTEND: Because the XTEND's IP address may not remain the same, any connection to it over Ethernet, e.g. to a virtual CNC, must use a host name. For more details see 'Host name' below.

Note that if any communication using a host name crosses a router(s), then a WINS server address must be set up.

Crossing Routers if DHCP is operating: In the DHCP regime, if the internetwork is to be built across a router(s), the devices in the remote devices table must be specified using their host names and subnet mask. This will enable the IP addresses to be obtained from the WINS servers. The remote devices table must contain the details of two devices in the network from each other subnet and be set up in every device on the local subnet. For increased reliability, details of additional devices should also be set up.

Manual Addressing

The XTEND can operate on an Ethernet system where the IP addressing information (IP address, subnet mask, default router, and WINS Server) are specified manually (i.e. the IP address is fixed). This is done using IPTool.

Connecting to a manually addressed XTEND: Connection to a XTEND over Ethernet, e.g. to a virtual CNC, can be made using either the host name or IP address. For more details see 'Host names' below.

Note that if any communication using a host name crosses a router(s), then a WINS server address must be set up.

Crossing Routers: If the internetwork is to be built across a router(s), the devices in the remote devices table can be specified using their host names and subnet mask, or IP address and subnet mask. The remote devices table must contain the details of the two devices with the lowest IP address in the network from each other subnet and be set up in every device on the local subnet. For increased reliability, details of additional devices should also be set up.

Link/Local Default Operation

XTEND, IQ3/IQ4 controllers, and IQView are set to automatic IP addressing by default. If a group of these devices are connected together on an Ethernet segment (without DHCP, WINS servers) they will power up in link/local and auto-negotiate their IP addresses. If they have been set up with device addresses and Lan numbers they will construct a Trend network. A supervisor or system tool running on a PC on the same segment will be able to communicate with them using host names (if the PC is set up for auto-addressing). Such a system cannot form a network across a router; this would require the setting up of DHCP and WINS servers and the remote devices table.

Host names

The XTEND has an additional addressing parameter, Host name, which provides a user-friendly method of accessing the XTEND e.g. when connecting to a virtual CNC, or building an internetwork across routers in a DHCP regime.

The host name defaults to TREND_xx_yy_zz where xx, yy and zz are the last 3 groups of the number in the XTEND's MAC address.

Using across routers: If the connection is to be across routers a Windows Internet Naming Service (WINS) server must be used to enable the device connecting to the XTEND to obtain the EINC L's IP address. Each device must be set up with the IP address of the WINS server. The XTEND sends its host name to the WINS server on power up. Devices wishing to communicate with XTEND send the host name to the WINS server which returns the associated IP address.

If a WINS server is not present the host name can only be used over the local segment (i.e. not across routers).

Using in a DHCP regime: Because the XTEND's IP address may not remain the same the host name must be used to connect to the XTEND when automatic addressing is being used.

Communication across the Internet: If connection to XTEND is to be made using the Internet then the firewall either has to be able to use the host name, or the XTEND's IP address must be fixed.

Remote Devices Table: The XTEND allows the address of remote devices to be specified using host names.

HARDWARE

Box

The XTEND is housed in a plastic case designed for DIN rail mounting. The unit must be installed either in a secondary enclosure or outside normal reach (e.g. in a plenum). The Trend ENCLS/MBOX/XTEND metal enclosure is suitable for this purpose.

The ENCLS/MBOX/XTEND box has an integral DIN rail and transformer mounting lugs. There are various knockouts for M20 (or ¾") conduit fittings in the back, sides, top and bottom of the box.

Power

The XTEND requires a 24 Vac (50/60 Hz) or 24 Vdc power supply. The maximum power consumption is 6 VA (or 100mA, 2.4W). Note that this power level cannot be provided from an IQ controller's auxiliary power output, so separate input power supply unit is required.

CAUTION: Do not connect mains voltage directly to this unit.

A suitable 230 Vac/24 Vac, 36 VA, transformer is available (ACC/24VAC). This is a sealed unit with four mounting lugs; it has an isolated 24 Vac output and an additional earth (ground) lead connected through from the input for earthing (grounding) the XTEND.

A general purpose 24 Vac transformer may also be used provided that it is rated at 6 VA or greater. Note that some transformers (as used in typical plant room installations) are earthed (grounded) on one side of the secondary; therefore care must be taken to ensure that the earthed (grounded) side of the transformer secondary is connected to the middle terminal of the XTEND's power connector.

Note that a switch or circuit breaker must be included in the input power to the unit and in close proximity to it, and it must be clearly marked as the disconnecting device for the unit.

Fusing: The PCB is protected by a 3.15 A fast-blow fuse. This protects the XTEND board from drawing excessive current. If it blows the unit should be returned to the supplier for repair.

Ethernet Port

The Ethernet port uses an RJ45 connector, and requires the specification of IP address, subnet mask, and default router. If required this information can be obtained from a DHCP server.

The XTEND supports 10/100 BASE-T. The 100 BASE-T network uses twisted pair cable (to IEEE 802.3) and the XTEND can run up to 100 Mbps. The maximum distance between the node and the hub is 100 m (109 yds). The XTEND should be connected to the hub using Cat 5e unshielded or shielded (UTP or FTP) cable and RJ45 plugs (shielded or unshielded appropriate to the cable).

LONWORKS Port

This port uses 2 part connectors with screw terminals for 0.5 to 2.5 mm² (20 to 14 AWG) cross section area cable.

The integral LONWORKS network transceiver uses FTT (or LPT) allows the use of free bus topology enabling star, bus, or loop wiring. It simplifies installation and facilitates network expansion. The bus uses two wires (twisted pair) which are polarity independent with no need for screen. The FTT runs at 78 k baud. The FTT LONWORKS network may already be present in a building, so the Trend system is able to make use of an existing building bus and hence reduce installation cost.

LONWORKS Network Terminator Switch: The LONWORKS network terminator switch enables the LONWORKS network to be terminated. It can be set to one of two positions:

- OFF (right) = no termination,
- FREE (left) = free topology termination 52Ω.

LON Service Button: Pressing the button generates an alarm message which would be forwarded a target alarm address (if set up) which identifies the originating XTEND by means of its Lon Neuron ID (NID).

Trend Current Loop Lan Port

This port uses 2 part connectors with screw terminals for 0.5 to 2.5 mm² (20 to 14 AWG) cross section area cable.

It can be wired for either 2-wire or 4-wire systems; for further details see "Connections" on page 18.

If the current loop is not to be connected (i.e. the unit is to only interface between Ethernet and LONWORKS) a loop back connector must be fitted.

Network Bypass Relay: In order that the current loop Lan continues to operate if the XTEND fails (e.g. power failure), a set of node bypass relays is fitted to maintain network integrity. The bypassing of a node will be recognised by the downstream node, and reported as a Lan Changed alarm.

Address Switch: The XTEND's device address on the local Lan is set to 126 (hard coded); and its Lan number (1, 4 to 9, 11 to 99) is selected by the address switch poles 1 to 7. It must be set to a Lan number unique on the internetwork and cannot be the same as any IQ3/IQ4 Lan number. When set to a value less than 100 the current loop will operate in INC mode when set to a value greater than or equal to 100 the current loop will operate in Internetwork Extension mode.

Baud Rate Switch: The baud rate on the Trend current loop network is set by address/ baud rate switch poles 8 to 10. It must be set to match other nodes on the Lan/internetwork. It may be set to 9k6, 19k2 or 38k4 baud.

Device Reset

Setting both the address and baud rate switches to zero for more than 3 seconds with power applied will reset the configuration parameters to the following default values:

- Address module (see list in firmware section)
- User module (clear)
- Router (clear)
- Virtual CNCs (clear)
- Remote EINCs (clear)

HARDWARE (continued)

Indicators

The XTEND has various LED indicators as detailed below:

Power/Status

:(green) Normally ON to indicate that the unit is powered and operating correctly. A slow double flash indicates that an IP address has not yet been established.

Current Loop network

TX :(yellow) ON indicates current flowing from the XTEND current loop network transmitter. OFF indicates open circuit between XTEND and the next device node.

RX :(yellow) ON indicates current flowing into the XTEND current loop network receiver. OFF indicates open circuit or short circuit between XTEND and the previous device node.

OK :(green) ON indicates that XTEND has successfully communicated with at least one other Trend system device on the current loop network. Flashes once every 15 seconds (approx.), for up to 60 seconds, while the current loop network is being built. If the LED continues to flash this indicates a LAN BROKEN condition (e.g. invalid address, incorrect baud rate, no connection or wiring fault).

Ethernet

OK :(green) ON indicates that XTEND has successfully communicated with at least one other Trend system device on the Ethernet and that an internetwork on Ethernet has been constructed. OFF indicates that XTEND is alone (e.g. using virtual CNCs only).

LINK :(green) ON if the XTEND has a good Ethernet connection. OFF indicates a faulty Ethernet connection.

DATA :(yellow) Flashes when a package of data is being received from the Ethernet network.

LONWORKS network

LON OK :(green) ON indicates that XTEND has successfully communicated with at least one other Trend system device on the LONWORKS bus. Flashes once every 24 seconds (approx.) while the internetwork on the LONWORKS bus is being built. Although the virtual Lans of IQLs will build in about 30s, it can take up to about 2½ minutes until the virtual internetwork on the LONWORKS network is completed after a LONWORKS network change.

Data Backup

Configuration data is stored in flash memory which is non-volatile in the case of power failure.

Firmware Upgrade

The XTEND has an SD card socket that will take an SD/MMC card (Secure Digital/Multimedia Card). This can be used for upgrades. Firmware upgrades will be supplied as a file that can be copied onto an SD card from a PC.

Labels

A small two-part label is attached to the front of XTEND which displays the unit's serial number and MAC address (in both text and barcode format). Space is provided on the label for recording the unit's O/S (outstation address), LAN number and IP address (if DHCP is not being used). It has a tear-off self-adhesive strip that also contains the serial number and MAC address (text and barcode) which can be adhered to a paper record, e.g. a log book.

FIRMWARE

The XTEND's firmware consists of a number of configuration modules (see table below) similar to the ones used in IQ controllers that enable XTEND's operation to be specified. These modules need to be set up as required before the XTEND will operate correctly.

Module Type	Configuration Prompts	Text Comms Module Identifier	Number of Modules
Address	R	R	1
Ethernet-ip	E	n2	1
Iq-lan	I	n1	1
Lontalk	L	n3	1
Remote EINC's	E	n/a (in n2)	20
Time	n/a	T	1
Updatelist	P	n/a	1
User	U	U	1
Virtual CNC	C	C	8

The initial configuration is best done using IPTool over Ethernet. This allows the configuration of the IP address, subnet mask, UDP port, Lan and network address, default router, virtual CNCs, and the remote devices table. The configuration of other module parameters must be done using the XTEND's configuration mode which provides access to all of the XTEND's parameters. Configuration mode is a built-in feature enabling the modules to be setup using the network (including across the internetwork), using any Trend system configuration utility.

When accessing the XTEND with IP Tool it can be identified from the list of devices by its MAC address. The XTEND can be accessed in configuration mode using any Trend system configuration utility connected to the IQ network. This connection can be made using Ethernet, or the current loop. A local PC may be connected using the Ethernet either by using an adjacent hub, or by direct connection using a standard Ethernet cable and then by using one of the XTEND's virtual CNCs. Once the configuration utility has connected to the IQ network the XTEND will be located from its local Lan at address 126 on Lan 0, and from the internetwork by device address 126 on its Lan number.

Configuration Mode

When an XTEND is accessed in configuration mode the top-level configuration mode menu is as follows:

```

Connecting to OS 126 Lan 0
XTEND EINC L v1.50 (lan 44)
addRes User virtual_Cncs
Iq-lan Ethernet-ip Lontalk
remote_Devices uPdate_remote devices
=?

```

The required options are selected by entering the relevant upper case letter and pressing **ENTER**. If a value has been changed **X+ENTER** will confirm it and return to the top menu, whereas **Q+ENTER** will quit and return with the value unchanged. Configuration mode may be protected by a password that will stop any changes being made until a valid password is entered.

Address Module

The address module stores the XTEND's addressing information and product specific non-network information. It has the following parameters:

Parameter	Description	Text Comms	Config Mode
Alarm Language	(read/write). The language used for the network alarms. 0=English, 1=Spanish, 2=Finnish, 3=Swedish, 4=Norwegian, 5=Danish, 6=German, 7=Italian, 8=Portuguese, 9=French. Default=0 (English)	P	P
Disable vCNC Alive Alarms	Enables/disables device on-line, and device dead alarms generated by the virtual CNCs. Range=Yes or No, Yes = alarms disabled, Default = No.		V
Flash image id	(read only). The device's flash image id.		
Generate inet remap alarms	Specifies whether internetwork remap alarms are generated. Range=Yes or No, Yes = alarms enabled, Default = Yes		M
Identifier	(read/write) A 40 character label used to identify the Lan. Default = TREND_xx_yy_zz. Where xx, yy, and zz are the last 3 groups of number in the Ethernet MAC address. 40 alphanumeric characters - not \{\};?* characters.	D	D
Internetwork Alarm Address	(read/write) The alarm target device address for internetwork alarms. It can be set to any valid address (1 to 119 excluding addresses 2, 3, and 10). 0 stops the alarms being transmitted. Default = 0	E	E
Internetwork Alarm Lan	(read/write) The alarm target Lan number for internetwork alarms. It can be set to any valid address (1 to 119 excluding addresses 2, 3, and 10). 0 stops the alarms being transmitted. Default = 0	T	T
Lan Alarm Address	(read/write) The alarm target device address for alarms generated by the current loop network when it is operating as a Lan. It can be set to any valid address (1 to 119 excluding addresses 2, 3, and 10). 0 stops the alarms being transmitted. Default = 0	A	A
Lan Alarm Lan	(read/write) The target Lan number for alarms generated by the current loop network when operating as a Lan. It can be any valid address (1 to 119 excluding 2, 3, and 10). 0 stops the alarms being transmitted Default = 0.	R	R
Lan Number	(read only) The Lan number of the Trend current loop connected to the internetwork by the XTEND if it is operating in INC mode. It is used to address the XTEND's virtual CNC, and the XTEND for configuration purposes when operating in internetwork extension mode. Range = (1 to 119 excluding addresses 2, 3, and 1). It is specified by the address switch setting. If the address is <100, the XTEND operates in INC mode and if =>100 it operates in internetwork extension mode.	N	
Product Code	(read only) The unit's serial number.	M	
Version	(read only) A 25-character string containing device type, prom issue, and date	C	

Ethernet-ip Module

The Ethernet-ipmodule stores the parameters specific to the Ethernet network. Each module has the following parameters:

Parameter	Description	Text Comms	Config Mode
Auto-ip-Addressing	(read/write) Specifies whether automatic or manual addressing is used. When automatic addressing is specified the XTEND's IP address, subnet mask, default router, and WINS server parameters are obtained from a DHCP server. If there is no DHCP server or it is not operating the IP address is autonegotiated with the other devices on the same subnet, and the IP subnet mask is set to 255.555.0.0 If manual addressing is selected the XTEND's IP address, subnet mask, default router, and WINS server parameters must be manually defined. Range = Yes or No, Yes = DHCP used, Default = Yes.	P	A
Default Router	(read/write) The IP address of the router to which messages are sent if the destination address is not on the local subnet. It should be set to the IP address of a router on the same subnet as the XTEND. It must be specified if the XTEND is to build an internetwork that spans routers, or if one of the virtual CNCs is to be used by a PC connected to an Ethernet subnet the other side of a router. When automatic addressing is specified it is obtained from a DHCP server. If there no DHCP server or it is not operating it is not set. If manual addressing is selected it must be manually defined, in this case it defaults to 0.0.0.0. Range = 0.0.0.0 to 255.255.255.255	R	R
Ethernet MAC Address	(read only) A unique number that identifies Ethernet chip; also used in default PIN generation process.	M	
Hostname	(read/write) A 15-character string that is registered with the network name server for connecting by name rather than IP address It defaults to TREND_xx_yy_zz. Where xx, yy, and zz are the last 3 groups of numbers in the MAC address. Range = 15 alphanumeric characters - not \{\};?* characters	\$	H

Ethernet-ip Module (continued)

Parameter	Description	Text Comms	Config Mode
IP Address	(read/write) The IP address of the XTEND. The IP address for each device on the Ethernet network must be unique to avoid address clashes. When automatic addressing is specified it is obtained from a DHCP server. If there no DHCP server or it is not operating it is autonegotiated with other devices on the same subnet. If manual addressing is selected it must be manually defined, in this case it defaults to 0.0.0.0. Range = 0.0.0.0 to 255.255.255.255	I	I
Networking Disabled	Specifies whether the device will search for other Trend devices on the Ethernet network.		D
WINS Server	(read/write) Specifies the IP address of the WINS Server. When automatic addressing is specified it is obtained from a DHCP server. If there no DHCP server or it is not set. If manual addressing is selected it must be manually defined, in this case it defaults to 0.0.0.0. Range = 0.0.0.0 to 255.255.255.255	W	W
Subnet Mask	(read/write) The subnet mask of the XTEND. The subnet mask must be the same for all devices not separated by routers that are to build Lans or an internetwork. This ensures that they are on the same subnet. When automatic addressing is specified it is obtained from a DHCP server. If there no DHCP server it is set to 0.0.0.0. If manual addressing is selected it must be manually defined, in this case it defaults to 255.255.255.0. Range = 0.0.0.0 to 255.255.255.255	S	S
UDP Port	(read/write) The UDP (User Datagram Protocol) port used by the XTEND to communicate with other Trend devices over the Ethernet network. All devices used to create an internetwork must use same port. Defaults to 57612. Range = 0 to 65535	E	U
Web Server Port	(read/write) The port number used to access the XTEND's web server, which allows web browser access to read only diagnostic information. Defaults to 80. Setting a value of 0 turns the web server off. Range = 1 to 32767	w	w

Iq-lan Module

The Lan network module stores the parameters specific to the IQ current loop network. Each Lan network module has the following parameters:

Parameter	Description	Text Comms	Config Mode
Baud Rate	(read only) Specifies baud rate of the Lan.	r	

Lontalk Module

The Lontalk module stores the parameters specific to the LONWORKS network. It has the following parameters:

Parameter	Description	Text Comms	Config Mode
Lontalk Enabled	Enables/disables the devices LONWORKS communications.		E
Lontalk Service Class	(read only) The device's lontalk service class.	a	S
Lontalk Retry Time	(read only) The device's lontalk retry time.	r	R
Lontalk Interpkt Time	(read only) The device's lontalk inter-packet time.	i	I
Lontalk Buffer Size	(read only) The device's lontalk buffer size.	b	
Lontalk Node	(read only) The node number.	n	
Lontalk Subnet	(read only) The device's lontalk subnet.	u	
Lontalk Domain	(read only) The device's lontalk domain.	d	
Lontalk Message Code	(read only) The device's message code.	m	
Lon Neuron ID (NID)	(read only) A unique number that identifies the neuron chip. It is used in default PIN generation process.	e	
Lontalk Managed	(read only) Indicates whether the device is installed in a Lon Management Tool. When set to No the node is not installed in a Lon Management Tool. This means that the read only parameters (node, subnet, domain, domain wide) will be left at their last setting (e.g. defaults), and the read/write parameter. Currently always No as installation in a Lon Management Tool is not supported.	l	
vLCI in Use	(read only) Indicates whether IqTool 2 is connected to one of the virtual CNCs		

Remote EINC Modules

The remote EINC modules store details of other devices that are to form part of the internetwork on Ethernet, allowing the internetwork to be built across routers. They form the remote devices table; each module is one entry in the table. There are 20 modules enabling up to 20 remote devices to be specified.

The remote devices table must contain the details of two devices on the internetwork from each other subnet and be set up in every device on the local subnet. If automatic addressing is being used the devices must be specified using their host names and subnet mask. If manual addressing is being used host names/IP address and subnet mask can be used, and the devices should be those with the lowest IP address. For increased reliability, details of additional devices should also be set up.

Parameter	Description	Text Comms	Config Mode
IP Address	(read/write) The IP address/host name of the remote device on Ethernet Range = 0.0.0.0 to 255.255.255.255. Default=0.0.0.0	(see note)	I
Send Remote Broadcasts	Specifies whether remote broadcast messages or directed messages are used to build the internetwork across routers. If set to use broadcast messages (Yes) the messages used to build the internetwork across routers will be sent to the default router requesting a broadcast message to all devices on the remote device's subnet as well as the remote device specified in the module. This has the advantage that if the remote device specified in the module has failed the messages will reach other devices on the that subnet and the internetwork can still be built. The broadcast message is sent to the subnet containing the remote device, it is therefore necessary to calculate what that is. This is done by applying the subnet mask to the IP address to give the subnet address of the remote device. E.g. subnet mask 255.255.255.0 with an IP address 171.171.10.2 gives the subnet address 171.171.10.0 which is used as the destination address for the broadcast messages. Note that the router may not allow broadcast messages. If set not to use broadcast messages (No) the messages used to build the internetwork across routers will only be sent (by direct messaging) to the device specified in the module. This option should only be turned off if the routers have remote broadcast messaging disabled. If broadcasting is turned off, details of as many device's as possible from each subnet should be entered in the remote devices table to enable the internetwork to be built in the event of a failure.		B
Subnet Mask	(read/write) The subnet mask for the remote device.Range = 0.0.0.0 to 255.255.255.255 Default=0.0.0.0	(see note)	S

*Note: The IP Address and Subnet Mask parameters are also accessible via text comms from the Ethernet-ip Module by using characters **b** and **s** respectively.*

Update List Module

The updatelist module enables the remote devices table in one XTEND to be copied to all the XTEND and EINC's in the table. Selecting P from the top-level configuration menu displays the following prompts.

Overwrite remote EINC list in all EINC(s) (Y/N)

If **Y** is entered, the list (including Broadcast/Directed flag status) will be copied to all the other devices on subnets that have at least one of their INC type node's details in the list. The devices will then be able to create the internetwork across the routers. The list should contain the XTEND's own details as well as details of at least two INC type nodes from every subnet to be linked by the internetwork. If broadcasting is not enabled, details of as many devices as possible from each subnet should be entered.

During the process the screen will show the progress of the operation. Any INC type node with a security enabled will require that PIN to be entered for its update to proceed.

Note that IPTool is recommended to keep the remote Trend devices list updated, so the update list function should not be used.

User Module

The user module provides password protection against changes made to XTEND parameters. There is only one password (PIN), and if set, this PIN must be entered before changes can be made. If the PIN is not correct the changes will be discarded.

If the PIN is forgotten, a default password can be obtained from Trend by quoting the generator number and the Ethernet MAC address. The default password may then be entered and the protection turned off, or the password changed to one that can be remembered. It has the following parameters.

User Module (continued)

Parameter	Description	Text Comms	Config Mode
Generator	(read only) A 4-digit number that is used to generate a PIN should the existing PIN be forgotten. Will only be correct for that session of configuration mode.	g	
PIN	(read/write) The 4-digit number that must be entered by the user to log on from a display, or must be sent by a tool/supervisor to authorise a change.	P	P

Virtual CNC Modules

The XTEND has eight virtual CNC modules. Which when enabled allow a supervisor to connect to the IQ network, or alarms to be sent to an IP address. They also enable a single connection to be made by IqITool 2 to the LONWORKS bus. Each module has the following parameters:

Parameter	Description	Text Comms	Config Mode
Alarm IP Address	(read/write) The host name or IP address of the alarm target supervisor that is connected to the Ethernet network if operating in alarm mode. This should be set up if the virtual CNC is being used as the destination address for alarm. Setting this up switches the virtual CNC into alarm mode, and prevents the virtual CNC being used as a CNC by a supervisor. 0 will switch the virtual CNC back into supervisor mode. Default=Unused	I	I
CNC Address	(read/write) The device address of the virtual CNC on XTEND's Lan. It is set to unused by default, and the virtual CNC will not operate until its address is set up. It can be set to any valid address (1 to 119 excluding addresses 2, 3, and 10). 0 will disable the virtual CNC.	A	A
Port Address	(read/write) The TCP port used by the virtual CNC. It is set unused by default and then defaults to 10000 plus the cnc address when the cnc address is set up, but can subsequently be changed. Range = 1 to 32767.	P	P

Text Communications

The XTEND has text communications capability. Text communications uses the text comms module identifier, module number, and the text comms parameter. E.g. U(P) Pin number, and R(D) iDentifier.

Identification

The XTEND replies to w comms with Internetwork Node Controller (INC) v4.00 or greater. The virtual CNCs reply with Communications Node Controller (CNC) v4.xx when they are not in use; when in use they will pass the w comms request on to the connected device.

Alarms

The XTEND helps to maintain a high level of network integrity by performing continuous checking of network messages. The following text alarms are generated when faults are found and sent to the specified address. It can deliver the alarms to two destinations set up in the address module: one for alarms from the internetwork, and another for alarms from the Lan.

The following alarms are generated when faults or state changes are found on the Trend current loop port when it is operating as a local Lan. They are sent to the address defined in the trend alarm addr section of the address module.

Alarm	Description	Alarm Code
LAN Broken	Indicates a break in the Lan communications.	NKBK
LAN Changed	A node has gone from or been added to the Lan.	NKCH
LAN OK	Lan communications are restored.	NKOK
Duplicate address	The XTEND's address is duplicated on the Lan (i.e. another address 126: another INC type node). Only generated after the Lan has been mapped.	NKDA

The alarms are in the format shown below:

Remote LAN From XtnD on Lan <xxx> - <Alarm> <Alarm Code>

Where <xxx> is the Lan number of the XTEND. <Alarm> is the alarm text as in the Alarm column of the table above. <Alarm Code> is the alarm code as in the Alarm Code column of table.

The following alarms are generated when faults or state changes are found on the Trend current loop port when it is operating as an internetwork segment. They are sent to the address defined in the internetwork alarm addr section of the address module.

Alarms (continued)

Alarm	Description	Alarm Code
Internetwork Broken	Indicates a break in the internetwork communications.	NKBK
Internetwork Changed	A node has gone from or been added to the internetwork.	NKCH
Internetwork OK	Internetwork communications are restored.	NKOK
Caused Re-Map	XTEND has started mapping its internetwork after a network change. This is only generated by devices whose address is > 100.	NKCH
All Maps Built	Lan mapping on the current loop internetwork finished. This is only generated by devices whose address is > 100.	NKCH

The following alarms are generated when faults of state changes are found on the Ethernet port. They are sent to the address defined in the internetwork alarm addr section of the address module.

Alarm	Description	Alarm Code
IP lwrk Broken	Indicates a break in the Ethernet internetwork communications.	NKBK
IP lwrk Changed	A node has gone from or been added to the Ethernet internetwork.	NKCH
IP lwrk OK	Ethernet internetwork communications are restored.	NKOK
IP Caused Re-Map	XTEND has started mapping its Ethernet internetwork after a an IP network change. This is only generated by devices whose address is > 100.	NKCH
IP All Maps Built	Internetwork mapping finished. This is only generated by devices whose address is > 100.	NKCH

The following alarms are generated when faults or state changes are found on the LonWORKS network port. They are sent to the address defined in the internetwork alarm addr section of the address module.

Alarm	Description	Alarm Code
Lon lwrk Broken	Indicates a break in the LonWORKS network internetwork communications.	NKBK
Lon lwrk Changed	A node has gone from or been added to the Lonworks internetwork.	NKCH
Lon lwrk OK	LonWORKS network internetwork communications are restored.	NKOK
Lon Caused Re-Map	XTEND has started mapping its LonWORKS internetwork after a Lan broken or Lan changed condition. This is only generated by devices whose address is > 100.	NKCH
Lon All Maps Built	Internetwork mapping on the LonWORKS network internetwork finished. This is only generated by devices whose address is > 100.	NKCH

The following alarm is generated when the XTEND's Lan number is duplicated on the internetwork. It is sent to the address defined in the internetwork alarm addr section of the address module.

Alarm	Description	Alarm Code
Duplicate address	The XTEND's Lan number address switch setting is duplicated on the internetwork. Only generated after the internetwork has been mapped.	NKDA

The alarms are in the format shown below:

Internetwork From Xtnd on Lan <xxx> - <Alarm> <Alarm Code>

Where <xxx> is the Lan number of the XTEND. <Alarm> is the alarm text as in the Alarm column of the table above. <Alarm Code> is the alarm code as in the Alarm Code column of table.

The following alarm is generated when the XTEND detects a node that thinks it is the only one on the network. It is sent to both alarm addresses defined in the address module.

Alarm	Description	Alarm Code
This node is deaf	This is generated when the XTEND hears another node that thinks it is the only node on the network. This will only occur if there is a hardware fault that enables a node to transmit but not receive, or the device's sub net is different to other on the same UDP port.	

The alarm is in the format shown below:

Internetwork IP<xxx.xxx> - <Alarm>

Where <xxx.xxx> is the last two numbers of the IP address of the device that thinks it is the only device on the network. <Alarm> is the alarm text as in the Alarm column of the table above.

FIELD MAINTENANCE

The XTEND requires no routine maintenance.



WARNING: Contains no serviceable parts. Do not attempt to open the unit. Failure to comply may cause damage to the unit.

DISPOSAL

COSHH (Control of Substances Hazardous to Health - UK Government Regulations 2002) ASSESSMENT FOR DISPOSAL OF XTEND. The only part affected is the lithium battery (on the battery option board) which must be disposed of in a controlled way.

RECYCLING

All plastic and metal parts are recyclable. The printed circuit board may be sent to any PCB recovery contractor to recover some of the components for any metals such as gold and silver.



WEEE Directive:

At the end of their useful life the packaging, product, and battery (if fitted) should be disposed of by a suitable recycling centre.
Do not dispose of with normal household waste.
Do not burn.

COMPATIBILITY

Supervisors/Displays	963 v2.1, 915MDS >v3, 916, IQView8
Utility software	SET v6 (including IP Tool software)
Controllers	IQ4x, IQ3x, also IQ1, IQ2, and IQL
Ethernet Nodes	Compatible with NXIP or EINC providing they are not used in an automatic IP addressing environment.
LONWORKS network	Not compatible with a LonWorks network that has been installed on a LonWorks Management Tool. A trend system can communicate with an installed LonWorks network using a TONN.

INSTALLATION

The XTEND must be mounted on a DIN rail and be installed in a secondary/protective enclosure rated to at least IP20 or equivalent (e.g. Trend ENCLS/MBOX/XTEND) or outside normal reach (e.g. in a plenum) The installation procedure involves:

- | | |
|---|------------------------------------|
| Mounting the unit | Reading End User Licence Agreement |
| Connecting power | Powering up |
| Connecting Ethernet if required | Configuring the unit |
| Connecting Trend current loop Lan if required | Checking LEDs |
| Connecting LONWORKS network if required | Testing the unit |

A full description of installation is given in the XTEND Installation Instructions TG201302 (mounting) and TG201303 (configuration).

CONNECTIONS

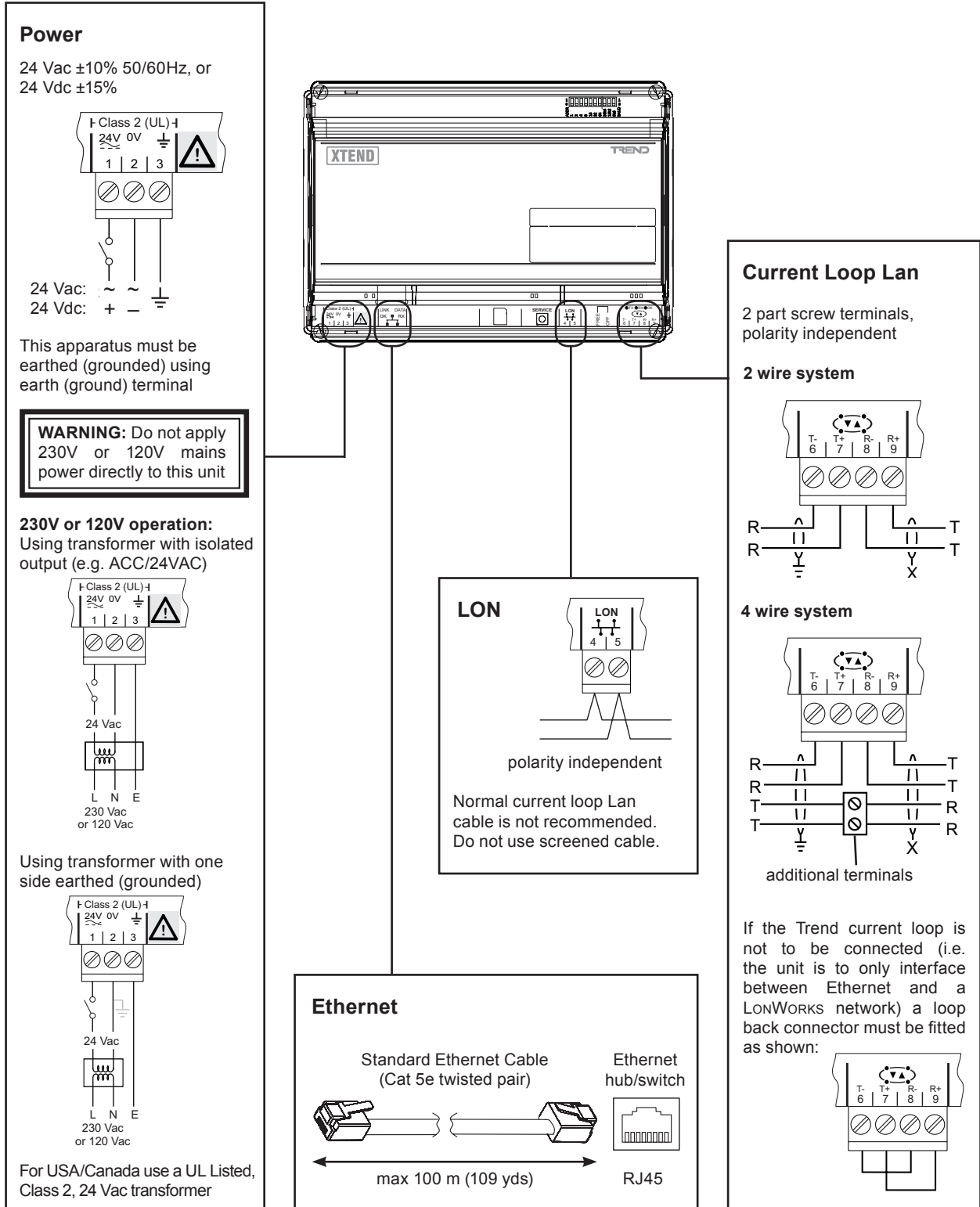

ORDER CODES

XTEND/24V XTEND for 24 Vac (or 24 Vdc) supply.

ACCESSORIES

ENCLS/MBOX/XTEND Metal enclosure (with integral DIN rail and transformer mounting).
ACC/24VAC 24 Vac, 36VA transformer for 230 Vac installation.
LONTERMINATOR Universal LONWORKS network terminator FTT, LPT-10, or TPT/XF1250 (see LONTERMINATOR data sheet TA200229).
IQLROUTER/24VAC IQL Router with 24 Vac power option.
IQLROUTER/230 IQL Router with 230 Vac power option.
IQLROUTER/USA/UL/24V IQL Router with 24 Vac power option.

SPECIFICATION

ELECTRICAL

CPU :Freescale iMX257
 CPU Speed :400 MHz
 Memory :32 Mbyte Flash, 128 Mbyte DDR2
 Input Power Supply :24 Vac ±10% 50/60Hz, or 24 Vdc ±15%.
 Power Consumption
 24 Vac :6 VA max.
 24 Vdc :100 mA, 2.4 W
 Fusing :3.15 A, fast blow fuse.
 Power Failure Protection :User configuration data is stored in internal flash memory.
 Current Loop Lan Transmission :20 mA, two wire current loop, opto-isolated, polarity independent receiver, balanced transmitter.
 Baud Rate :9k6, 19k2 or 38k4 baud, selectable by onboard switches. Set to match other nodes on Lan.
 Lan Number :1 to 119, selectable by onboard switches. Must be unique for each node on internetwork; addresses 2,3, and 10 are not permitted.
 Distance :Distance between units dependent on baud rate and cable type (see below).

Cable	9k6 baud	19k2 baud	38k4 baud	No. of Wires
Belden 9182	1000 m (1090 yds)	700 m (765 yds)	500 m (545 yds)	2
Belden 9207	1000 m (1090 yds)	500 m (545 yds)	350 m (380 yds)	2
Trend TP/1/1/22/HF/200 (Belden 8761)	700 m (765 yds)	350 m (380 yds)	250 m (270 yds)	2
Trend TP/2/2/22/HF/200 (Belden 8723)	500 m (545 yds)	250 m (270 yds)	125 m (1135 yds)	4

Ethernet Port
 Transmission :10/100 BASE-T auto-negotiated
 Distance :100 m (109 yds) to hub
 LONWORKS Network :FTT (Free Topology), 78 k baud, transformer isolated. Single termination (RC network). Can also use LPT10 (Loop Powered free Topology).

LON Transceiver :FT5000
 LON Signal Transformer :FT-X3
 LON FTT Distance :Maximum bus length and node to node distance depend on cable type.

Recommended Cables	Max bus length	Max node to node
Belden 85102	500 m (545 yds)	500 m (545 yds)
Trend TP/1/0/16/HF/200 (Belden 8471)	500 m (545 yds)	400 m (430 yds)
UL Level IV, 22 AWG	500 m (545 yds)	400 m (430 yds)
JY(St) Y2 x 2 x 0.8	500 m (545 yds)	320 m (350 yds)
TIA568A Cat. 5, 24 AWG	450 m (490 yds)	250 m (270 yds)

Note that this does not include cable recommended for the current loop Lan.

Storage Media :SD card socket takes SD/MMC card (Secure digital/Multimedia card) for firmware upgrades.
 Device Address :The address of the XTEND on the Lan is 126. The 8 virtual CNC addresses are set in configuration mode, to be unique on Lan; 116 nodes addressable (1 to 119, excluded addresses 2,3, and 10).

INDICATORS

Power/Status :Green/Red Bi-colourLED
 Current Loop
 TX :Yellow LED
 RX :Yellow LED
 OK :Green LED
 Ethernet
 OK :Green LED
 LINK :Green LED
 DATA :Yellow LED
 LONWORKS Network
 LON OK :Green LED

SPECIFICATION (continued)

MECHANICAL

Dimensions	:206 mm (8.11") x 145mm (5.70") x 58 mm (2.28").
Weight	:569 g (1.25 lb)
Material	
Box	:Flame retardant PCABS
Terminal Covers	:Polycarbonate
DIN Rail Clip	:Glass-filled nylon
Connectors	
Current Loop Lan	:2 part connector with screw terminals for 0.5 to 2.5 mm ² cross section area (20 to 14 AWG) cable.
Ethernet	:RJ45 connector, unshielded or shielded twisted pair (UTP or FTP) cable 10 Mbps, 100 m (109 yds), 10 BASE-T. Cable and connectors are available (see product codes). Connect local supervisor (Ethernet) using adjacent hub or directly using standard Ethernet cable and XCITE/XA adapter.
Supply	:2 part connector with screw terminals for 0.5 to 2.5 mm ² cross section area (20 to 14 AWG) cable.
LON	:2 part connector with screw terminals for 0.5 to 2.5 mm ² cross section area (20 to 14 AWG) cable.
SD	:SD card slot for SD or MMC cards.

ENVIRONMENTAL

EMC	:EN61326-1:2006
Immunity	Table 2 for equipment used in industrial locations
Emissions	:Class B
Safety	
EU	:EN60950-1: 2006
CB Scheme	:Certificate number NO76403
USA/Canada	:UL rated as 'UL916 listed open energy management equipment' (E219709).
Canada	:CSA22.2 No. 205-M1983 - Signal Equipment.
Ambient Limits	
Storage	:-30 °C (-22 °F) to 60 °C (140 °F)
Operating	:-25 °C (-13 °F) to 55 °C (131 °F)
Humidity	:0 to 90 %RH, non-condensing
Altitude	:<2000m (6562 ft)
Pollution Degree	:2 (only non-conducting pollution occurs)
Protection	:IP20, NEMA1

© Echelon Corporation. Echelon, LON, Neuron, LonWorks are U.S. registered trademarks of Echelon Corporation. LONMARK is a trademark of Echelon Corporation.

Please send any comments about this or any other Trend technical publication to techpubs@trendcontrols.com

© 2014 Honeywell Technologies Sàrl, ECC Division. All rights reserved. Manufactured for and on behalf of the Environmental and Combustion Controls Division of Honeywell Technologies Sàrl, Z.A. La Pièce, 16, 1180 Rolle, Switzerland by its Authorized Representative, Trend Control Systems Limited.

Trend Control Systems Limited reserves the right to revise this publication from time to time and make changes to the content hereof without obligation to notify any person of such revisions or changes.

Trend Control Systems Limited

Albery House, Springfield Road, Horsham, West Sussex, RH12 2PQ, UK. Tel:+44 (0)1403 211888 Fax:+44 (0)1403 241608 www.trendcontrols.com

Trend Control Systems USA

6670 185th Avenue NE, Redmond, Washington 98052, USA. Tel:(425) 869-3900 Fax:(425) 869-8445 www.trend-americas.com