



FCM 300 Series

Instruction Manual

MG.03.B6.22 Document Version 2.0

Software version 2.1x
The software version number
is displayed in parameter 624

Chapter 1	Safety	page 1-1
	■ Warnings	page 1-2
	■ Safety Precautions	page 1-3
	■ Warning Against Unintended Start	page 1-3
<hr/>		
Chapter 2	General Technical Data	page 2-1
	■ Specifications	page 2-2
	■ General Technical Data	page 2-2
<hr/>		
Chapter 3	Dimensions	page 3-1
	■ Product Dimensions	page 3-2
<hr/>		
Chapter 4	Ordering	page 4-1
	■ Ordering information	page 4-2
	■ Ordering form	page 4-7
<hr/>		
Chapter 5	Product Concept	page 5-1
	■ Integrating an AFD and motor	page 5-2
<hr/>		
Chapter 6	Installation	page 6-1
	■ Mechanical installation	page 6-2
	■ Motor information	page 6-4
	■ Terminal Specifications	page 6-6
	■ Electrical Installation	page 6-8
<hr/>		
Chapter 7	Operation	page 7-1
	■ Start-up	page 7-2
	■ Control Options	page 7-2
	■ Local Control Panel	page 7-5
<hr/>		
Chapter 8	Parameter Group 0: Operation & Display	page 8-1
	■ Parameters 001-019	page 8-2
<hr/>		
Chapter 9	Parameter Group 1: Load & Motor	page 9-1



FCM 300 Series

■ Parameters 100-139	page 9-2
<hr/>	
Chapter 10 Parameter Group 2: References & Limits	page 10-1
■ Parameters 200-231	page 10-2
<hr/>	
Chapter 11 Parameter Group 3: Inputs & Outputs	page 11-1
■ Parameters 317-340	page 11-2
<hr/>	
Chapter 12 Parameter Group 4: Special Functions	page 12-1
■ Parameters 400-446	page 12-2
<hr/>	
Chapter 13 Parameter Group 5: Serial Communication	page 13-1
■ Parameters 500-543	page 13-2
<hr/>	
Chapter 14 Parameter Group 6: Technical Functions	page 14-1
■ Parameters 600-635	page 14-2
<hr/>	
Chapter 15 Serial Communication	page 15-1
■ Danfoss PC Software	page 15-2
■ Serial bus	page 15-3
■ Telegram Communication	page 15-3
■ Telegram Build-up	page 15-3
■ Data Bytes	page 15-4
<hr/>	
Chapter 16 Messages	page 16-1
■ List of Warnings and Alarms	page 16-2
■ What if the Motor Does Not Start?	page 16-2
■ Warnings	page 16-3
■ Warnings Words 1+2 and Alarm Word	page 16-5
<hr/>	
Chapter 17 CE / EMC	page 17-1



FCM 300 Series

- CE Labeling page 17-2
- The Machinery Directive (89/392/EEC) . page 17-2
- The Low-Voltage Directive /73/23/EEC)page 17-2
- The EMC Directive (89/336/EEC) page 17-2
- Compliance with EMC Directive(89/336/EEC) page 17-2
- What is Covered? page 17-2
- Danfoss VLT® DriveMotor & CE Labeling page 17-3
- Galvanic Isolation (PELV) page 17-3
- Ground Leakage Current page 17-4
- Acoustic Noise page 17-4
- Balance page 17-4
- Extreme Running Conditions page 17-4
- EMC Standards page 17-5
- Harsh Environments page 17-6

Chapter 18 Special Conditions page 18-1

- Derating page 18-2
- Derating for Ambient Temperature and
for running at low speed page 18-2
- Derating for Air Pressure page 18-2
- Derating for High Switching Frequency . page 18-3
- Vibration and Shock page 18-3
- Air Humidity page 18-3
- Efficiency page 18-3
- Harmonics page 18-4
- Power Factor page 18-4

Chapter 19 Parameters page 19-1

- Factory Parameter Settings page 19-2

Chapter 20 Index page 20-1

- Index page 20-2



FCM 300 Series

Chapter 1

- Warnings page 1-2
- Safety Precautions page 1-3
- Warning Against Unintended Start page 1-3

WARNING

The FCM 300 Series unit contains dangerous voltages when connected to line voltage. After disconnection from the line, wait at least 4 minutes before touching any electrical components. Also make sure that other voltage inputs have been disconnected. Only a competent electrician should carry out the electrical installation. Improper installation of the FCM 300 Series unit may cause equipment failure, serious injury or death. Follow this manual and the National Electrical Codes (NEC[®]) and local safety codes.

WARNING

Electrostatic Precaution: Electrostatic discharge (ESD). Many electronic components are sensitive to static electricity. Voltages so low that they can not be felt, seen or heard, can reduce the life, affect performance, or completely destroy sensitive electronic.

When performing service, proper ESD equipment should be used to prevent possible damage from occurring.

CAUTION

It is the responsibility of the user or the person installing the FCM 300 to provide proper grounding and branch circuit protection according to the National Electrical Code (NEC[®]) and local codes.

Motor overload protection is internal to the unit.

Safety Precautions

1. The FCM 300 unit must be disconnected from the AC line if repair work is to be carried out. After the AC supply has been disconnected, be sure the necessary time (4 min.) has passed before removing line terminal wires.
2. The "Stop/Reset" key on the optional local control pad or local operating panel of the FCM 300 unit DOES NOT disconnect the equipment from the AC line and is NOT to be used as a safety switch.
3. The installer must supply correct protective grounding of the equipment and the user must be protected against supply voltage in accordance with the National Electrical Code and local codes. Class 20 motor overload protection is provided internally.
4. The ground leakage currents are higher than 3.5 mA.
5. Use lifting points, if provided. Lift FCM 300 units vertically only. Lifting points are provided to support the weight of the FCM 300 only - do not use lifting points when additional equipment is attached.
6. Before installation, check unit for fan cover damage, foot/mounting damage, shaft damage and loose fasteners. Check nameplate data on motor.
7. FCM 300 types 311-375 (over 44 lb/20 kg) should be positioned by lifting machines only - for your safety, do not attempt hand lifting. Refer to "Handling the FCM 300" on page 6-5 for actual weights.
8. Installation must be correctly fused and isolated per CE directives.

Warning Against Unintended Start

1. The unit can be brought to a stop by means of digital commands, bus commands, references or a local stop, while the FCM 300 unit is connected to the AC line. These stop functions are NOT sufficient to ensure that no unintended start occurs and should NOT be used for personal safety considerations.
2. While parameters are being changed, the motor may start.
3. A FCM 300 unit that has been stopped may start if faults occur in the electronics of the unit, or if a temporary overload occurs or if there is an interruption in the AC line supply.



FCM 300 Series



FCM 300 Series

Chapter 2

- Specificationspage 2-2
- General Technical Datapage 2-2



FCM 300 Series

General Technical Data

■ FCM 305-375 for 3 phases, 380-480 V

FCM	305	307	311	315	322	330	340	355	375
Motor output									
[HP]	0.75	1.0	1.5	2.0	3.0	4.0	5.0	7.5	10.0
[kW]	0.55	0.75	1.1	1.5	2.2	3.0	4.0	5.5	7.5
Motor torque									
2 pole [Nm]	1.8	2.4	3.5	4.8	7.0	9.5	12.6	17.5	24.0
4 pole [Nm]	3.5	4.8	7.0	9.6	14.0	19.1	25.4	35.0	48.0
Frame									
size [mm]	56	56	143	145	182	182	184	213	215
Weight [kg]	11	13	17	20	26	28	37	56	61
Input current									
380 V									
2 p	1.4	1.6	2.2	2.8	4.1	5.3	7.0	9.3	13.0
4p	1.4	1.7	2.5	3.3	4.7	6.4	7.9	11.1	15.3
480 V									
2 p	1.2	1.3	1.8	2.3	3.3	4.2	5.6	7.4	10.2
4 p	1.1	1.4	2.0	2.6	3.7	5.1	6.4	8.8	11.9
Power terminals									
[AWG]	10	10	10	10	10	10	10	6	6
[mm ²]	4	4	4	4	4	4	4	10	10
Gland sizes	3XPG16*	3XPG16*	3XPG16*	3XPG16*	3XPG16*	3XPG16*	3XPG16*	1XPG21/ 3XPG16*	1XPG21/ 3XPG16*
Max. prefuse									
UL ¹⁾ [A]	10	10	10	10	10	15	15	25	25
IEC ¹⁾ [A]	25	25	25	25	25	25	25	25	25

* PG to NPT adapters can be ordered separately. See page 4-5.

¹⁾ To comply with UL/cUL, the prefuses must be Bussmann KTS-R 500 V or Ferraz Shawmut, type ATMR (max. 30A). The fuses must provide protection in a circuit capable of supplying a maximum of 100,000 amps RMS (symmetrical), 500 V maximum.

■ General technical data

AC line supply, TT, TN and IT* (L1, L2, L3):

- Supply voltage 380-480 V units 3 x 380/400/415/440/460/480 V ±10%
- Supply frequency 50/60 Hz
- Max. imbalance of supply voltage ±2% of rated supply voltage
- Power factor / cos φ max. 0.9/1.0 at rated load
- Switching on supply input L1, L2, L3 approx. 1 time/2 min

See chapter 18, "Special conditions".

*) Not valid for RFI class 1B units

Torque characteristics:

- Starting torque/overload torque 160 % for 1 min
- Continuous torque see page 18-2

Control card, digital/pulse inputs:

- Number of programmable digital inputs 4
- Terminal nos. X101-2, -3, -4, -5
- Voltage level 0-24 V DC (PNP positive logics)
- Voltage level, logic '0' < 5 V DC
- Voltage level, logic '1' > 10 V DC
- Maximum voltage on input 28 V DC
- Input resistance, R_i approx. 2 k Ω
- Scanning time 20 msec

Control card, pulse input:

- No. of programmable pulse inputs 1
- Terminal nos. X101-3
- Max. frequency on terminal 3, open collector/push pull 24 V 8 kHz/70 kHz
- Resolution 10 bit
- Accuracy (0.1-1 kHz), terminal 3 Max. error: 0.5% of full scale
- Accuracy (1-12 kHz), terminal 3 Max. error: 0.1% of full scale

Control card, analog inputs:

- No. of programmable analog voltage inputs 1
- Terminal nos. X101-2
- Voltage level 0 - 10 V DC (scalable)
- Input resistance, R_i approx. 10 k Ω
- No. of programmable analog current inputs 1
- Terminal no. X101-1
- Current range 0 - 20 mA (scalable)
- Input resistance, R_i approx. 300 Ω
- Resolution 9 bit
- Accuracy on input Max. error 1% of full scale
- Scanning time 20 msec.

Control card, digital/pulse and analog outputs:

- No. of programmable digital and analog outputs 1
- Terminal nos. X101-9
- Voltage level at digital output/load 0 - 24 V DC/25 mA
- Current at analog output 0 - 20 mA
- Maximum load to frame (terminal 8) at analog output $R_{LOAD} \leq 500 \Omega$
- Accuracy of analog output Max. error: 1.5% of full scale
- Resolution on analog output 8 bit

Control card, RS 485 serial communication:

- Terminal nos. X100-1, -2

Control characteristics (adjustable frequency drive):

- Frequency range 0 - 132 Hz
- Resolution on output frequency 0.1 %
- System response time Max. 40 msec.



FCM 300 Series

Chapter 3

■ Dimensionspage 3-2

■ Dimensions
Foot mounting - B3

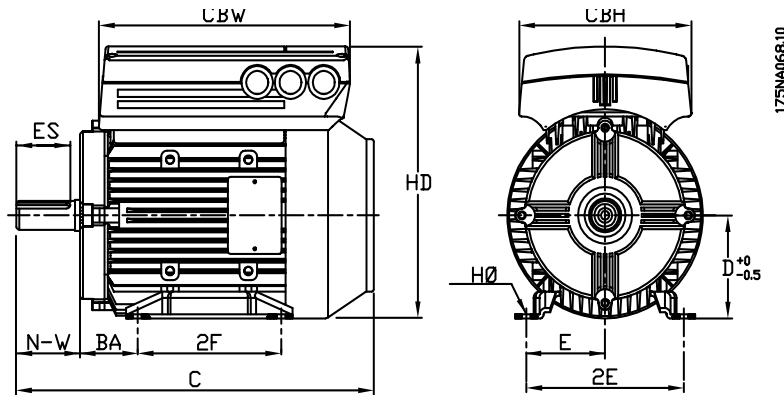

General

FCM	305	307	311	315	322	330	340	355	375
Frame size	56	56	143T	145T	NA	NA	184T	213T	215T
HP	0.75	1.0	1.5	2.0	-	-	5.5	7.5	10.0
2E [in]	4.875	4.875	5.5	5.5	-	-	7.5	8.5	8.5
BA [in]	2.75	2.75	2.25	2.25	-	-	2.75	3.5	3.5
D [in]	3.5	3.5	3.5	3.5	-	-	4.5	5.25	5.25
HØ [in]	0.344	0.344	0.344	0.344	-	-	0.5	0.5	0.5
2F [in]	3	3	4	5	-	-	4	5.5	7
C [in]	12.25	12.25	13	13	-	-	15.78	17.781	17.781
CBW [in]	8.11	8.11	9.06	9.06	-	-	11.26	13.38	13.38
CBH [in]	5.55	5.55	6.22	6.22	-	-	7.76	9.25	9.25
HD [in]	8,98	8,98	9,31	9,31	-	-	11,50	13,14	13,14

Shaft Drive End

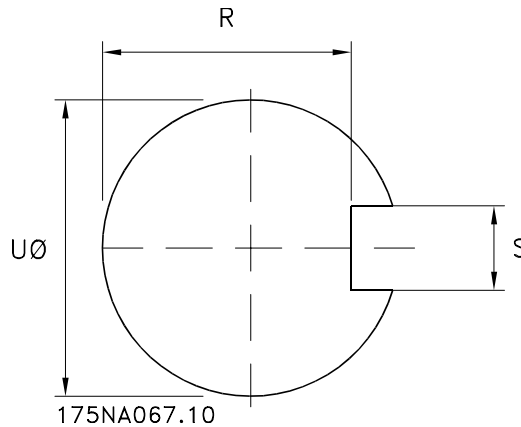

FCM	305	307	311	315	322	330	340	355	375
Frame size	56	56	143T	145T	182T	182T	184T	213T	215T
HP	0.75	1.0	1.5	2.0	3.0	4.0	5.5	7.5	10.0
UØ [in]	0.625	0.625	0.875	0.875	1.125	1.125	1.125	1.375	1.375
N-W [in]	1.875	1.875	2.25	2.25	2.75	2.75	2.75	3.25	5.575
ES [in]	1.375	1.375	1.406	1.406	1.75	1.75	1.75	2.375	2.375
S [in]	0.188	0.188	0.188	0.188	0.25	0.25	0.25	0.313	0.313
R [in]	0.517	0.517	0.771	0.771	0.986	0.986	0.986	1.201	1.201

FCM 300 Series

Flange mounting - B5, B35 (B3+B5)

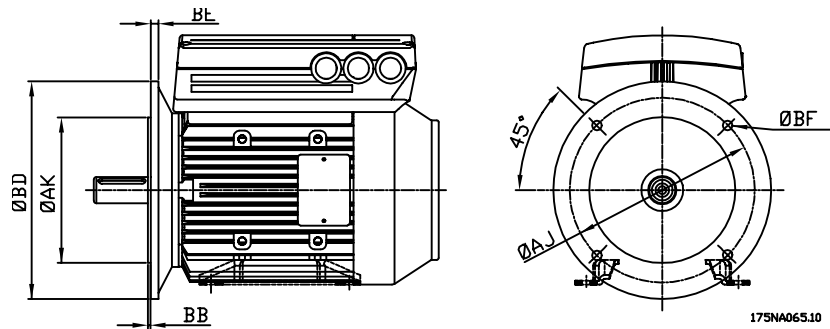

B5

FCM	305	307	311	315	322	330	340	355	375
Frame size	NA	NA	143	145	182	182	184	213	215
HP	-	-	1.5	2.0	3.0	4.0	5.5	7.5	10.0
ØAJ [in]	-	-	10	10	10	10	10	10	10
ØAK [in]	-	-	9	9	9	9	9	9	9
ØBD [in]	-	-	11	11	11	11	11	11	11
ØBF [in]	-	-	0.531	0.531	0.531	0.531	0.531	0.531	0.531
BB [in]	-	-	0.25	0.25	0.25	0.25	0.25	0.25	0.25
BE [in]	-	-	0.5	0.5	0.50	0.50	0.5	0.5	0.5

Face mounting - B14, B34 (B3+B14)

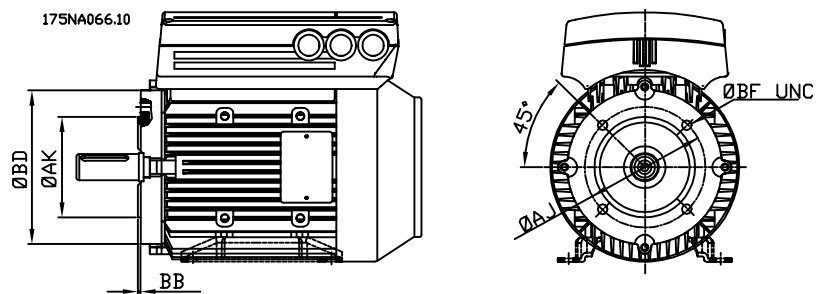

B14

FCM	305	307	311	315	322	330	340	355	375
Frame size	56	56	143	145	182	182	184	213	215
HP	0.75	1.0	1.5	2.0	3.0	4.0	5.5	7.5	10.0
ØAJ [in]	5.575	5.875	8.575	5.875	5.875	7.25	7.25	7.25	7.25
ØAK [in]	4.5	4.5	4.5	4.5	4.5	8.5	8.5	8.5	8.5
ØBD [in]	6.5	6.5	6.5	6.5	6.5	9	9	9	9
ØBF UNC [in]	0.375	0.375	0.375	0.375	0.375	0.5	0.5	0.5	0.5
BB [in]	0.125	0.125	0.125	0.125	0.156	0.156	0.25	0.25	0.25

Chapter 4

- Ordering information overview page 4-2
- Product range VLT® DriveMotor
FCM 300 Series page 4-4
- Ordering information for
frames and flanges page 4-6



FCM 300 Series

Ordering

Ordering Information Overview

■ Code Numbers for 2 Pole Motors with HVAC Parameter Setting H

Type Nema Ref	HP	Phases Voltage	Hardw. Variant	Foot	D Flange	C Face	Foot & D Flange	Foot & C Face
FCM305 56	0.75	T4 3 phase 380-480 V	ST	176H1578	NA	176H1579	NA	176H1580
			SP	176H1581	NA	176H1582	NA	176H1583
FCM307 56	1.0		ST	176H1584	NA	176H1585	NA	176H1586
			SP	176H1587	NA	176H1588	NA	176H1589
FCM311 143	1.5		ST	176H1590	176H1591	176H1592	176H1593	176H1594
			SP	176H1595	176H1596	176H1597	176H1598	176H1599
FCM315 145	2.0		ST	176H1600	176H1601	176H1602	176H1603	176H1604
			SP	176H1605	176H1606	176H1607	176H1608	176H1609
FCM322 182	3.0		ST	NA	176H1610	176H1611	NA	NA
			SP	NA	176H1612	176H1613	NA	NA
FCM330 182	4.0		ST	NA	176H1614	176H1615	NA	NA
			SP	NA	176H1616	176H1617	NA	NA
FCM340 184	5.5		ST	176H1618	176H1619	176H1620	176H1621	176H1622
			SP	176H1623	176H1624	176H1625	176H1626	176H1627
FCM350 213	7.5		ST	176H1628	176H1629	176H1630	176H1631	176H1632
			SP	176H1633	176H1634	176H1635	176H1636	176H1637
FCM375 215	10.0	ST	176H1638	176H1639	176H1640	176H1641	176H1642	
		SP	176H1643	176H1644	176H1645	176H1646	176H1647	

■ Code Numbers for 2 Pole Motors with HVAC Parameter Setting H

Type Nema Ref	HP	Phases Voltage	Hardw. Variant	Foot	D Flange	C Face	Foot & D Flange	Foot & C Face
FCM305 56	0.75	T4 3 phase 380-480 V	ST	176H1648	NA	176H1649	NA	176H1650
			SP	176H1651	NA	176H1652	NA	176H1653
FCM307 56	1.0		ST	176H1654	NA	176H1655	NA	176H1656
			SP	176H1657	NA	176H1658	NA	176H1659
FCM311 143	1.5		ST	176H1660	176H1661	176H1662	176H1663	176H1664
			SP	176H1665	176H1666	176H1667	176H1668	176H1669
FCM315 145	2.0		ST	176H1670	176H1671	176H1672	176H1673	176H1674
			SP	176H1675	176H1676	176H1677	176H1678	176H1679
FCM322 182	3.0		ST	NA	176H1680	176H1681	NA	NA
			SP	NA	176H1682	176H1683	NA	NA
FCM330 182	4.0		ST	NA	176H1684	176H1685	NA	NA
			SP	NA	176H1686	176H1687	NA	NA
FCM340 184	5.5		ST	176H1688	176H1689	176H1690	176H1691	176H1692
			SP	176H1693	176H1694	176H1695	176H1696	176H1697
FCM350 213	7.5		ST	176H1698	176H1699	176J1700	176H1701	176H1702
			SP	176H1703	176H1704	176H1705	176H1706	176H1707
FCM375 215	10.0	ST	176H1708	176H1709	176H1710	176H1711	176H1712	
		SP	176H1713	176H1714	176H1715	176H1716	176H1717	



FCM 300 Series

Ordering

■ Code Numbers for 2 Pole Motors with Industrial Parameter Setting I

Type Nema Ref	HP	Phases Voltage	Hardw. Variant	Foot	D Flange	C Face	Foot & D Flange	Foot & C Face
FCM305 56	0.75	T4 3 phase 380-180V	ST	176H1864	NA	176H1865	NA	176H1866
			SP	176H1867	NA	176H1868	NA	176H1869
FCM307 56	1.0		ST	176H1870	NA	176H1871	NA	176H1872
			SP	176H1873	NA	176H1874	NA	176H1875
FCM311 143	1.5		ST	176H1876	176H1877	176H1878	176H1879	176H1880
			SP	176H1881	176H1882	176H1883	176H1884	176J1885
FCM315 145	2.0		ST	176H1886	176H1887	176H1888	176H1889	176H1890
			SP	176H1891	176H1892	176H1893	176H1894	176H1895
FCM322 182	3.0		ST	NA	176H1896	176H1897	NA	NA
			SP	NA	176H1898	176H1899	NA	NA
FCM330 182	4.0		ST	NA	176H1900	176H1901	NA	NA
			SP	NA	176H1902	176H1903	NA	NA
FCM340 184	5.5		ST	176H1904	176H1905	176H1906	176H1907	176H1908
			SP	176H1909	176H1910	176H1911	176H1912	176H1913
FCM350 213	7.5		ST	176H1914	176H1915	176H1916	176H1917	176H1918
			SP	176H1919	176H1920	176H1921	176H1922	176H1923
FCM375 215	10.0		ST	176H1924	176H1925	176H1926	176H1927	176H1928
			SP	176H1929	176H1930	176H1931	176H1932	176H1933

■ Code Numbers for 4 Pole Motors with Industrial Parameter Setting I

Type Nema Ref	HP	Phases Voltage	Hardw. Variant	Foot	D Flange	C Face	Foot & D Flange	Foot & C Face
FCM305 56	0.75	T4 3 phase 380-480 V	ST	176H1934	NA	176H1935	NA	176H1936
			SP	176H1937	NA	176H1938	NA	176H1939
FCM307 56	1.0		ST	176H1940	NA	176H1941	NA	176H1942
			SP	176H1943	NA	176H1944	NA	176H1945
FCM311 143	1.5		ST	176H1946	176H1947	176H1948	176H1949	176H1950
			SP	176H1951	176H1952	176H1953	176H1954	176H1955
FCM315 145	2.0		ST	176H1956	176H1957	176H1958	176H1959	176H1960
			SP	176H1961	176H1962	176H1963	176H1964	176H1965
FCM322 182	3.0		ST	NA	176H1966	176H1967	NA	NA
			SP	NA	176H1968	176H1969	NA	NA
FCM330 182	4.0		ST	NA	176H1970	176H1971	NA	NA
			SP	NA	176H1972	176H1973	NA	NA
FCM 340 184	5.5		ST	176H1974	176H1975	176H1976	176H1977	176H1978
			SP	176H1979	176H1980	176H1981	176H1982	176H1983
FCM350 213	7.5		ST	176H1984	176H1985	176H1986	176H1987	176H1988
			SP	176H1989	176H1990	176H1991	176H1992	176H1993
FCM375 215	10.0		ST	176H1994	176H1995	176H1996	176H1997	176H1998
			SP	176H1999	176H2000	176H2001	176H2002	176H2003

FCM 300 Series

■ Product range VLT® DriveMotor FCM 300 Series, 2/4 poled motors

Type	Motor output	Mains supply
FCM 305	0.75 HP	3 phase 380-480 V
FCM 307	1.0 HP	
FCM 311	1.5 HP	
FCM 315	2.0 HP	
FCM 322	3.0 HP	
FCM 330	4.0 HP	
FCM 340	5.0 HP	
FCM 355	7.5 HP	
FCM 375	10.0 HP	

Each type in the product range is available in different versions.

Inverter versions

Drive control:

- *ST*: Standard version
- *SP*: Version for PROFIBUS

RFI filter:

Inverter with integrated RFI filter, class A1 (industrial) or class B1 (domestic).

Cooling:

- TEFV: Motor cooled by a shaft mounted fan (IC 411)
- FV: Motor cooled by an independent fan (IC 416) (Not UL)

Mounting versions

- Foot mounting (B3)
- Flange mounting (B5)
- Face mounting (B14)
- Foot + flange mounting (B35)
- Foot + face mounting (B34)

See chapter 6.

Inverter box position: Top, right side or left side.

Drainhole (+ position): None, between feet, opposite feet, vertical drive end, vertical non-drive end, 90° right of feet, 90° left of feet.

■ NEMA Ordering

Take a copy of the ordering forms on page 4-8. Fill in and post or fax your order to the nearest branch office of the Danfoss sales organisation. On the basis of your order, the FCM 300 Series motor is given a type code, which may look as follows:

FCM 355-P-T4-ST-S55-R2-0213T-4-1-B03-213-T-00

This means that the ordered FCM300 is an FCM355 7,5 HP, three-phase mains voltage of 380 - 480V +/- 10%, T4 and for process application P. The inverter is a standard version for remote control ST in a NEMA 12/IP55 enclosure S55 with integrated RFI filter, class B1 R2. The motor frame size and version is 213T which is a foot mounted motor 0213T. The motor has 4 poles 4 and is cooled by the shaft-mounted fan 1. The motor is a foot mounted motor B03 and the frame is 213. The inverter box is mounted on the top of the motor I and no drain hole is placed 00.

As an example the above motor with D flange, inverter on the right side, drain hole position between feet

FCM355-P-T4-ST-S55-R2-0213T-4-1-B05-213-R-D1

If you wish to place your order by using the type code directly, please use the codes given in parenthesis on the left-hand side of the ordering forms. The code sequence in the type code is stated at the top of each part of the form (character number).

The ordering form for the basic unit must always be completed. When the type code is written, always state the characters of the basic string (1-30).

Together with the order confirmation the customer receives an 8-figure code number to be used when reordering.



FCM 300 Series

Danfoss PC software for serial communication

All FCM 300 Series units come standard with an RS 485 port to communicate with a PC using Danfoss VLT® Dialog Software (see page 7-3).

Ordering numbers, VLT® Software Dialog

VLT® Software Dialog	175Z0953
----------------------	----------

Incl Basic, Logging, Template, Guided tour modules in 6 languages (Danish, English, German, Italian, Spanish and French)

Accessories for the FC motor

A Local Operation Pad (LOP) for local set point and start/stop is available for the FC motor. The LOP is IP 66 enclosed. A Local Control Panel (LCP 2) which makes up a complete interface for operation, programming and monitoring of the FC motor is also available.

Ordering numbers, accessories

Local Operation Pad (LOP)	175N0128
Local Control Panel (LCP 2)	175N0131
Remote mounting kit (LCP 2)	175N0160
Plug kit (LCP 2)	175N0161
Cable for plug kit (LCP 2)	175N0162
Cable (direct mounting) (LCP 2)	175N0165
Service plug kit (LCP 2)	175N0166
PG 16 to ½" NPT adapter	176H9207
PG 21 to ¾" NPT adapter	176H9208

■ NEMA Ordering info for Flange, Face and Foot Versions

Frame sizes and the corresponding flange sizes for different mounting versions

Type	Frame size version			Motor flange size 2 and 4 pole motors
	Foot	Flange	Face	
FCM305	00056	NA	0056C	056
FCM307	00056	NA	0056C	056
FCM311	0143T	143TD	143TC	143
FCM315	0145T	145TD	145TC	145
FCM322	NA	182TD	182TC	182
FCM330	NA	182TD	182TC	182
FCM340	0184T	184TD	184TC	184
FCM355	0213T	213TD	213TC	213
FCM375	0215T	215TD	215TC	215

■ Ordering info for inverter box position and drain hole position seen from drice end side.

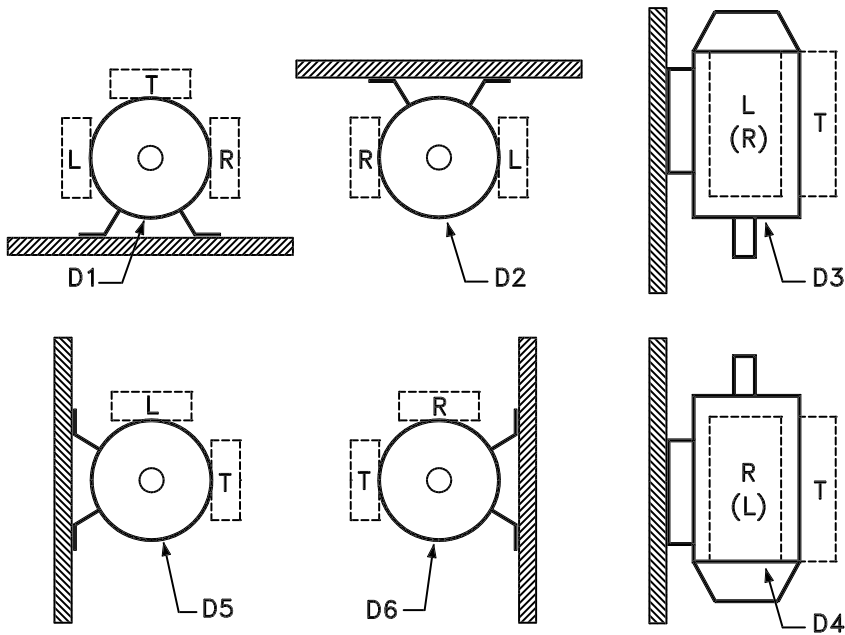

175NA058.10



FCM 300 Series

Ordering form FCM 300 Series

FCM type (character nos. 1-6)

Select the required FCM type from the product range on the previous page and fill in the squares.

Application range (char. no. 7)

(P) **Process**

Mains voltage (char. nos. 8-9)

(T4) **3-phase 380-480 V AC**

Tick off as appropriate.

Inverter vs. (char. nos. 10-11)

(ST) **Standard**

(SP) **PROFIBUS**

Tick off as appropriate.

Enclosure (char. no. 12-14)

(S55) NEMA 12 **IP55**

(S56) **IP56**

(S66) **IP66**

RFI filter (char. nos. 15-16)

(R1) **W/ integrated filter, class A1**

(R2) **W/integrated filter, class B1**

Tick off as appropriate.

Frame size and version

(char. nos. 17-21)

Fill in the squares with the appropriate value from column 2 and 3 in the table on page 4-7.

Polarity (char. no. 22)

(4) **4 poles**

(2) **2 poles**

Tick off as appropriate.

Cooling (char. no. 23)

(1) (IC 411) **Shaft mounted fan**

(6) (IC 416) (not UL) **Forced ventilation unit**

Tick off as appropriate.

Ordering form FCM 300 Series

Mounting vs. and flange size (char. nos. 24-29)

(B03) **Foot** **0 0 0**

(B05) **Flange** **flange size**

(B35) **Foot & flange** **flange size**

(B14) **Face** **flange size**

(B34) **Foot & face** **flange size**

Tick off as appropriate and select flange size from the table on page 4-7.

Inverter box position (char. no. 30)

(T) **Top**

(R) **Right side**

(L) **Left side**

Tick off as appropriate.

Inverter box position is seen from drive end.

(See drawing on page 4-7).

Drain hole position (char. nos. 31-32)

(00) **None**

(D1) **Between feet**

(D2) **Opposite feet**

(D3) **Vertical drive end**

(D4) **Vertical non-drive end**

(D5) **90° right of feet**

(D6) **90° left of feet**

Tick off as appropriate.

(See drawing on page 4-7).

Other options (contact Danfoss for code)

Number of FCM 300 Series ordered

Ordered by:

Date: _____



FCM 300 Series

Chapter 5

■ Product Concept..... page 5-2

FCM 300 Series

■ Integration of adjustable frequency drive and motor

The Danfoss VLT® adjustable frequency drive integrated onto the asynchronous motor gives infinite speed control in one unit.

The VLT® FCM 300 Series is a very compact alternative to the traditional solution with a VLT adjustable frequency drive and motor as separate units. The adjustable frequency drive is attached in place of the motor terminal box, and it is no higher than the standard terminal box, nor wider or longer than the motor (see page 3-2).

Installation is made extremely easy. Panel space is not a problem. There is no need for special details on wiring to meet the EMC directive, since motor

cables are not necessary. The only connections are the AC line and control connections.

Factory-set adaption between the adjustable frequency drive and motor gives precise and energy efficient control in addition to reducing installation time.

The FCM 300 can be used in stand alone systems with traditional control signals, such as start/stop signals, speed references and closed loop process control or in multiple drive systems with control signals distributed by a fieldbus.

Combination of fieldbus and traditional control signals and closed loop PID control is possible. Also possible is a combination fieldbus and traditional control signals and closed loop PID control.

■ Control structures

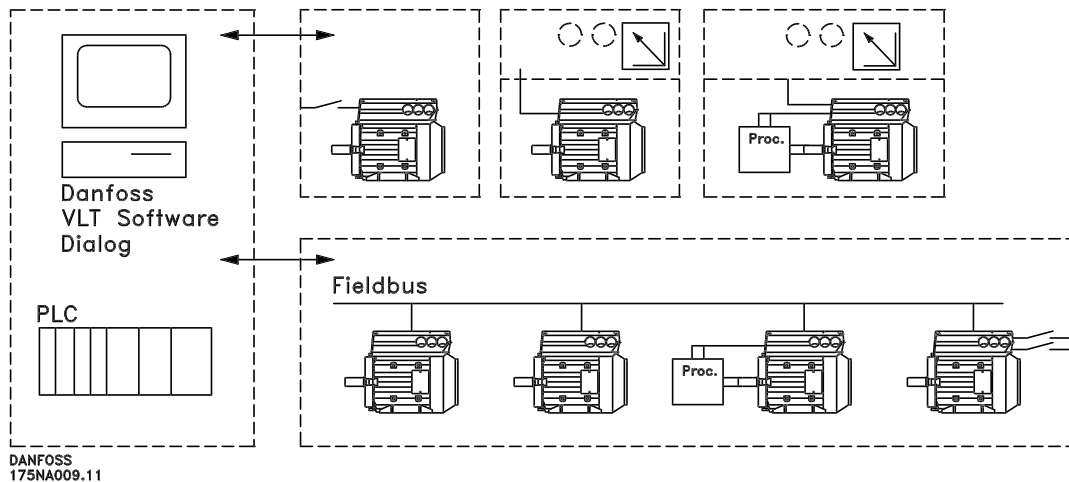

■ Block diagram for FCM 300 Series

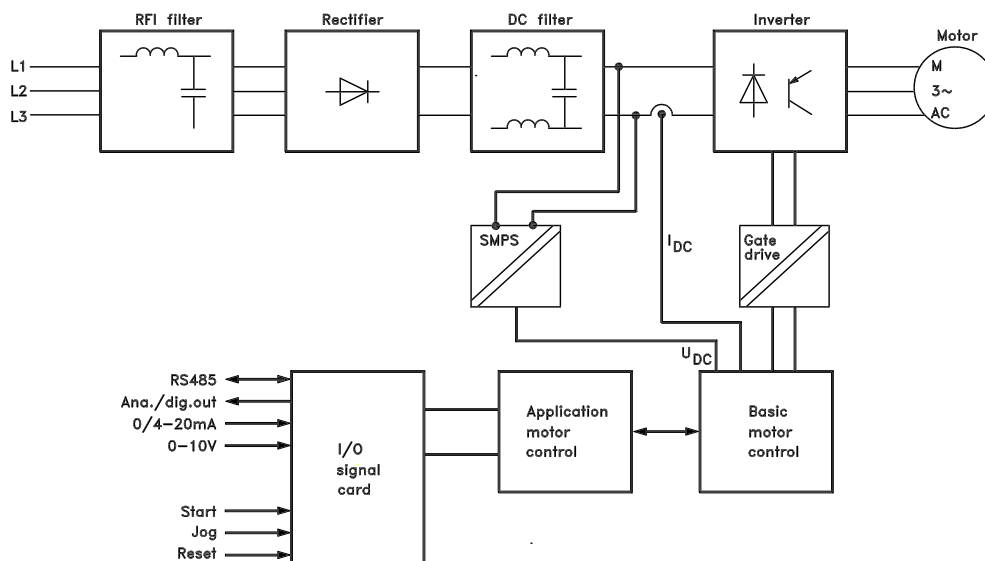

175NA010.11

Chapter 6

- **Mechanical Installation**
 - Mounting Clearances page 6-2
 - Alignment page 6-2
 - Maximum axial and radial loads
 - Standard Ball Bearings page 6-2
 - Angular Contact Bearings page 6-3
 - Bolt Torques page 6-3
 - Maintenance page 6-3

- **Motor information**
 - Motor Description page 6-4
 - Handling the FCM 300 page 6-5
 - Bearings page 6-5
 - Output Shafts page 6-5

- **Terminal Specifications** page 6-6
 - Terminal and Switch Locations page 6-6
 - Connection Diagram page 6-6
 - Tightening Torques page 6-7
 - Maximum Cable Cross Section page 6-7
 - Screw Sizes page 6-7

- **Electrical Installation** page 6-8
 - AC line fuses page 6-8

■ Mechanical Installation of the FCM 300



Do not force fittings couplings, pulleys, etc. onto the FCM 300 motor shaft, as this will cause bearing damage, increasing bearing noise and significantly reducing bearing life.

To avoid overheating, the ambient temperature should not exceed 104 °F/40 °C. The average 24-hour temperature is not to exceed 95 °F/35 °C. For more information, see "Derating".

Before installation, check unit for fan cover damage, foot/mounting damage, shaft damage and loose fasteners. Check nameplate data on motor.

The FCM 300 unit should not be mounted such that the inverter portion of the unit (regardless of feet position) is upside down.

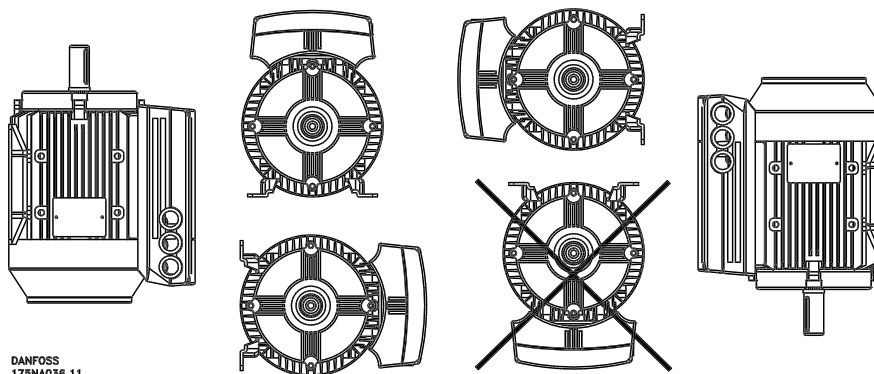

■ Alignment

When the application calls for direct coupling, the shafts must be correctly aligned in all three planes. Bad alignment can be a major source of noise and vibration.

■ Mounting Clearances

FCM 300 units must be installed with adequate access for routine maintenance.

Minimum clearance = 29.5 in (0.75 m) on all sides
Minimum clearance at fan inlet = 2 in. (50 mm)

Where several units are installed in close proximity, care must be taken to ensure warm air from units is not recirculated.

FCM 300 units must be mounted on rigid, level surfaces.

■ Fitting Pinions, Pulleys and Coupling

These should be sized to fit FCM 300 standard dimensions.

Allowance must be made for shaft endfloat and thermal expansion in both axial and vertical planes. It is preferable to use flexible drive couplings.

Maximum permissible external axial and radial loads in N (1N = 0.225 lbf) standard ball bearings

Frame size	Poles	Horizontal shaft		Vertical shaft				Max. radial ²
		Load towards motor	Load away from motor	Shaft up		Shaft down		
				load	load	load	load	
80	2	275	441	481	245	294	432	638
	4	373	549	569	343	392	520	785
90	2	412	638	598	294	373	520	824
	4	540	765	716	402	471	628	903
100	2	853	853	932	932	814	814	1207
	4	1010	1010	1118	1118	961	961	1393
112	2	853	853	932	932	814	814	1207
	4	1010	1010	1118	1118	961	961	1393
132S	2	1059	1403	1570	952	1216	1305	1785
	4	1265	1609	1825	1138	1472	1481	1972
132M	4	1256	1609	1854	1109	1501	1462	2040

¹ All figures are based on L_{na} bearing life of 20,000 hours.

L_{na} = adjusted L₁₀ life rating taking account of: -Reliability -Material improvements -Lubrication conditions

² Max. permissible radial load at end of shaft (horizontal mounting).



FCM 300 Series

Maximum permissible external axial and radial loads in N (1N = 0.225 lbf) angular contact bearings

Frame size	Poles	Horizontal shaft		Vertical shaft				Max. radial ²		
		Load towards motor		Load away from motor		Shaft up			Shaft down	
		motor	from motor	load	load	load	load			
80	2	1375	2205	2405	1225	1470	2160	3190		
	4	1865	2745	2845	1715	1960	2600	3925		
90	2	2060	3190	2990	1470	1865	2600	4120		
	4	2700	3825	3580	2010	2355	3140	4515		
100	2	4265	4265	4660	4660	4070	4070	6035		
	4	5050	5050	5590	5590	4805	4805	6965		
112	2	4265	4265	4660	4660	4070	4070	6035		
	4	5050	5050	5590	5590	4805	4805	6965		
132S	2	5295	7015	7850	4760	6080	6525	8925		
	4	6325	8045	9125	5690	7360	7405	9860		
132M	4	6280	8045	9270	5545	7505	7310	10200		

¹ All figures are based on L_{na} bearing life of 20,000 hours.

L_{na} = adjusted L10 life rating taking account of: -Reliability -Material improvements -Lubrication conditions

² Max. permissible radial load at end of shaft (horizontal mounting).

■ Foot Mounting Bolt Torques

Face/Flange, feet and lid should be secured with the bolt sizes and torque's detailed in the table below.

Foot mounting bolt torques

FCM Type	Frame size	Bolt diameter	Torque
			Nm.
305-307	80	M8 (taptite)	24-25
311-315	90	M8 (taptite)	24-25
322-330	100	M8 (taptite)	32-35
340	112	M8 (taptite)	32-35
355-375	132	M8 (taptite)	32-35

Face/Flange bolt torques

FCM Type	Frame size	Bolt diameter	Torque
			Nm
305-307	80	M5	5
311-315	90	M5	5
322-330	100	M6 (taptite)	8-10
340	112	M6 (taptite)	8-10
355-375	132	M6 (taptite)	8-10

LID screws torque: 2.2 - 2.4 Nm, Plastic plug (cable entrance) torque: 2.0 Nm

1 Nm = 1.196 lb-ft

■ Maintenance

Routine cleaning of the FCM 300

Remove the fan cover and ensure that all air inlet holes are completely clear. Clean any dirt and obstructions from behind the fan and along the ribs of the frame, and between the motor and inverter.

Periodic maintenance of motor.

- Remove the inverter, the fan cover and the fan which is keyed to the shaft extension. Loosen and remove bearing cover screws and endshield bolts/studs. The endshields should then be eased off their spigots.
- The rotor can now be carefully withdrawn from the stator, taking care not to damage the stator bore and both stator and rotor windings.
- Having dismantled the motor, maintenance can be carried out to remove all dirt. For this purpose, the use of an air line supplying dry compressed air under comparatively low pressure is best, as a high velocity air-stream can force dirt into the spaces between the

windings and insulation, etc. Grease-removing solvents can cause damage to impregnating varnish or insulation

- The FCM 300 should be re-assembled in the reverse order from dismantling, remembering to ease endshields onto bearings and spigots. DO NOT USE FORCE.
- Before starting, check that the rotor spins freely. Ensure that the electrical connections are correct.
- Refit any pulley, coupling, sprocket etc. which has been removed, being particularly careful to ensure correct alignment with the driven part, as misalignment will lead to ultimate bearing trouble and shaft breakage.
- When replacing screws and bolts, care should be taken to use only those with the grade recommended by the manufacturer. These must also be of identical thread form and screw/bolt length (see the table above).

■ Motor Information

The FCM 300 consists of the following parts:

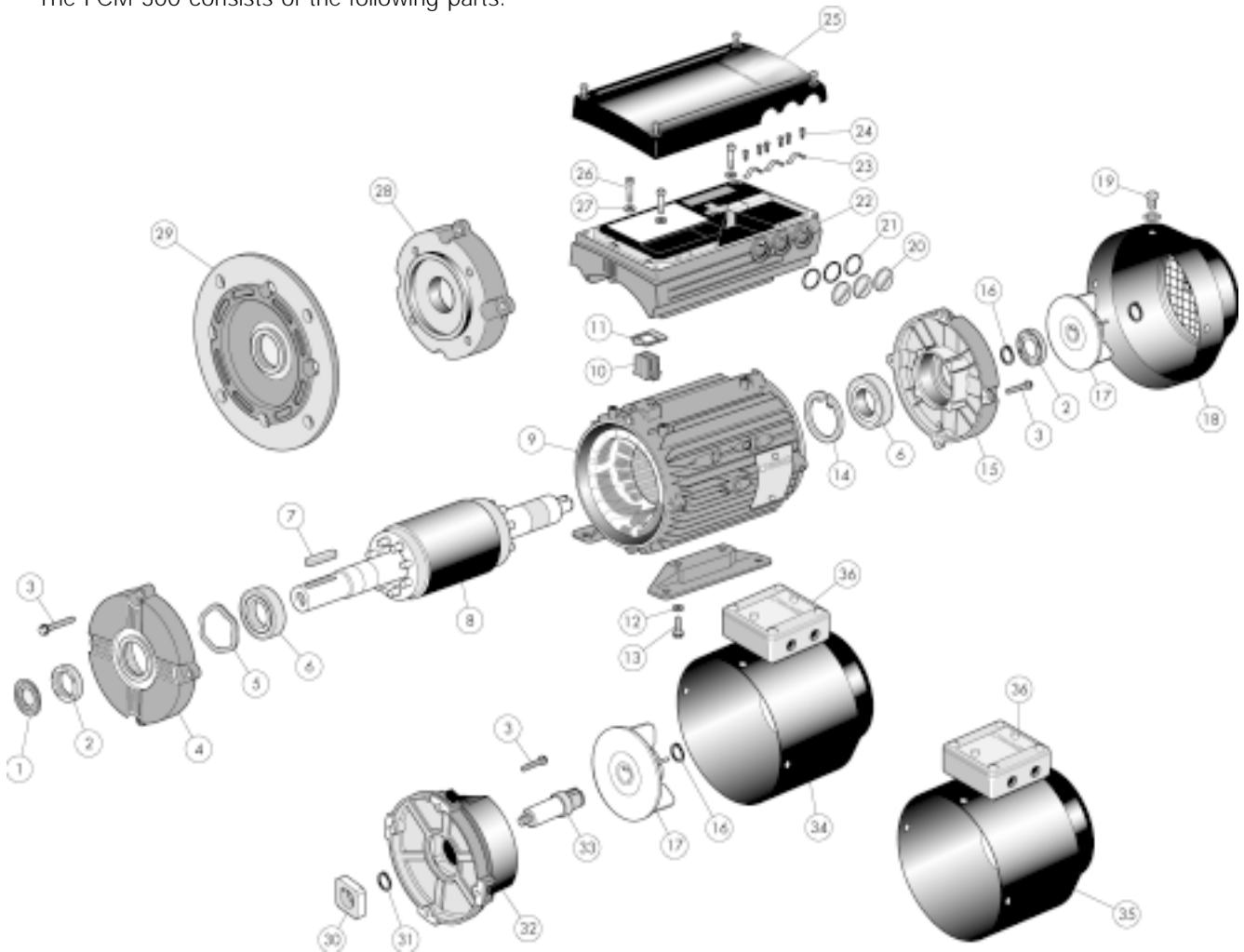

Item	Description
1	Slinger (when fitted)
2	Drive end oilseal
3	Endshield fixing bolt
4	Drive end endshield
5	Preload washer
6	Bearing
7	Shaft key
8	Rotor assembly
9	Stator assembly with or without feet
10	Connector block
11	Gasket
12	Detachable feet
13	Foot mounting bolt and washer
14	Bearing retention circlip
15	Non-drive endshield
16	Bearing circlip
17	Fan
18	Fan cover

Item	Description
19	Fan cover screw and washer
20	Plastic cable entrance plugs
21	O' ring
22	ISM box
23	Cable strap
24	Cable strap screws
25	ISM box lid
26	Torx screw
27	Washer
28	Face endshield
29	Flange endshield
30	Brake hub
31	Brake hub retention circlip
32	Brake and adaptor plate
33	Stub shaft
34	Brake fan cover
35	Force vent fan cover
36	Terminal box

FCM 300 Series

■ Handling the FCM 300

Handling and lifting of VLT® DriveMotors (FCM 300 units) must only be undertaken by qualified personnel. Full product documentation and operating instructions must be available together with tools and equipment necessary for safe working practice. Eyebolts and/or lifting points supplied with the FCM 300 are designed to support only the weight of the FCM 300, not the weight of the FCM 300 and any auxiliary equipment attached to it. Be absolutely sure that cranes, jacks, slings and lifting beams are capable of carrying the weight of equipment to be lifted.

Where an eyebolt is provided with the motor,

this should be screwed down until its shoulder is firmly against seated the face of the stator frame to be lifted.

FCM type	approx. weight (kg.)	lbs
FCM 305	11	24,3
FCM 307	13	28,7
FCM 311	17	37,5
FCM 315	20	44,1
FCM 322	26	57,3
FCM 330	28	61,7
FCM 340	37	81,6
FCM 355	56	123,5
FCM 375	61	134,5

■ Bearings

To avoid static indentation, the storage area should be vibration free. Where exposure to some vibration is unavoidable, the shaft should be locked. Bearings may be fitted with a shaft locking device which should be kept in place during storage. Shafts should be rotated by hand, one quarter of a revolution, at weekly intervals.

Lubrication

FCM	Lubrication type	Temperature range
305 - 375	Esso unirex N3	-10 + 140°C/ -14 + 284°F

Bearing life

Maximum hours bearing life (L_{na}) expected at 80° C/176°F bearing temp. x 10³ hours.

FCM	3600 rpm		3000 rpm		1800 rpm		1500 rpm	
	Horiz.	Vert.	Horiz.	Vert.	Horiz.	Vert.	Horiz.	Vert.
305-315	20	20	22	22	30	30	32	32
322-340	22	22	26	26	33	33	35	35
355-375	22	22	26	26	33	33	35	35

L_{na} bearing life is the adjusted, L10 life rating, taking account of: -Reliability -Material improvement -Lubrication conditions.

Standard Bearing references and oil seals

FCM	Mounting	Poles (2/4)	Bearings		Oil seals - Bore x O/D x width in mm	
			Drive end	Non-drive end	Drive end	Non-drive end
305-307	All	All	6204 2Z	6202 2Z	20 x 30 x 7	15 x 24 x 5
311-315	All	All	6205 2Z	6203 2Z	25 x 35 x 7	17 x 28 x 6
322-330	All	All	6206 2Z	6205 2Z	30 x 42 x 7	25 x 37 x 7
340	All	All	6206 2Z	6205 2Z	30 x 42 x 7	25 x 37 x 7
355-375	All	All	6208 2Z	6305 2Z	40 x 52 x 7	25 x 37 x 7

NOTE!

Ball and roller bearings are shipped from the factory fully charged with grease. Sealed bearings have sufficient grease for at least two years of continuous operation in normal ambient temperatures (see General Specifications).

■ Output shafts

Output shafts are produced from 35/40 Ton (460/540 MN/m²) tensile steel. Drive end shafts are provided with a tapped hole to DIN 332 Form D and a closed profile keyway as standard.

Balance

All motors are dynamically balanced, to ISO 2373 with key convention to IEC 34-14.

Inertia

FCM	J [kgm ²]*	
	2 pole	4 pole
305	0.0015	0.0019
307	0.0015	0.0027
311	0.0024	0.0035
315	0.0024	0.0047
322	0.006	0.009
330	0.007	0.010
340	0.008	0.016
355	0.017	0.027
375	0.020	0.032

* 1 kgm² = 23.73036 lbf²

Terminal Specifications

To access terminals, remove the inverter top cover, which is held in place by 4 screws.

Terminal blocks X100 and X101 should be removed to make the AC Line terminals more accessible.

Lift the corner of the protective black plastic to expose the AC Line terminals (L1, L2 and L3). **DO NOT** remove the plastic cover!

Remove necessary PG plastic plugs to insert AC Line cable and control cables. Use as many openings as necessary. PG to NPT adapters are sold separately.

Terminal and Switch Locations

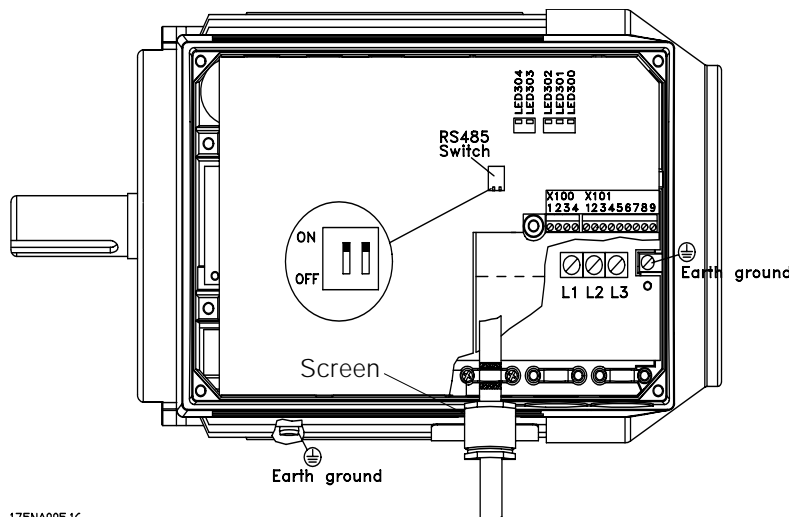

175NA005.16

X101: Terminal block for analog/digital control signals

Terminal No.	Function	Example
1	Analog input (0-20 mA)	Feedback signal
2	Analog (0-10 V)/digital input 2	Speed reference
3	Digital input (or pulse) 3	Reset
4	Digital input (or precise stop) 4	Start
5	Digital input (other) 5	Jog (fixed speed)
6	24 V DC supply for digital inputs (max. 150 mA)	
7	10 V DC supply for potentiometer (max. 15 mA)	
8	0 V for terminals 1-7 and 9	
9	Analog (0-20 mA)/digital output	Fault indication

X100: Terminal block for data communication

Terminal No.	Function
1	P RS 485 for connection to
2	N RS 485 bus or PC
3	5 V DC Supply for RS 485 bus
4	0 V DC

For terminating an RS 485 serial communication interface, units at both ends of the bus must have their RS 485 switch turned to ON.

LED 300-304

LED 300 (red):	Fault trip
LED 301 (yellow):	Warning
LED 302 (green):	Power on
LED 303-304:	Communication

For PROFIBUS versions please refer to the manual MG90AXYY.

The RS 485 connector interfaces with the service plug kit (part#176N0166) when both serial communication and the LCP-2 are to be used simultaneously.

Connection diagram - factory setting

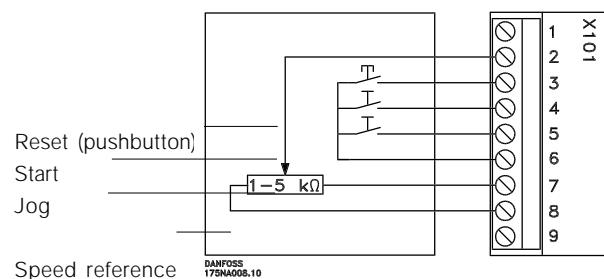

- *Reset* to be closed short time for resetting fault trips
- *Start* to be closed for changing to *run mode*
- *Jog* will run at fixed speed while closed (10 Hz)
- *Speed reference* (0-10 V) determines speed while in *run mode*



FCM 300 Series

■ Tightening Torques

Cover (lid) screws:	19.5 - 21.2 lb-in (2.2 - 2.4 Nm)
Plastic cable entrance plugs:	19.5 lb-in (2.2 Nm)
L1, L2, L3 (AC Line) screws (FCM 305-340):	5 - 7 lb-in (0.5 - 0.6 Nm)
L1, L2, L3 (AC Line) screws (FCM 355-375):	15 lb-in (1.2 - 1.5 Nm)
Earth Ground:	30.1 lb-in (3.4 Nm)

Terminal screws require a max 2.5 mm flat-blade screwdriver.

AC Line screws require a 8mm flat-blade screwdriver.

Earth ground and cable clamp screws all require T-20 Torx or flat-blade screwdriver.

Lid screws require Philips screwdriver.

■ Maximum Cable Cross Section

Note:

Use %60 C copper wire or better

	AWG	mm ²
Max size AC Line cable (FCM 305-340):	10	4.0
Max size AC Line cable (FCM 355-375):	6	10
Max size control cable:	16	1.5
Max size serial communication cable:	16	1.5
Earth Ground:	6	10

■ Screw Sizes

Cover (lid) screws:	M5
Earth Ground and Cable Clamp screws (FCM 305-340):	M4
Earth Ground and Cable Clamp screws (FCM 355-375):	M5

FCM 300 Series

■ Electrical Installation



CAUTION!

The FCM 300 Series unit contains dangerous voltages when connected to line voltage. After disconnecting from the line, wait at least 4 minutes before touching any electrical components. Also make sure that other voltage inputs have been disconnected.

Only competent electricians should carry out the electrical installation. Improper installation of the FCM 300 Series unit may cause equipment failure, serious injury or death. Follow this manual and National Electrical Codes (NEC®) and local safety codes and guidelines.

To avoid potential shock hazard when servicing the unit, remove all power to all units that share any conduit to be worked on.

In general, a conduit should not contain unshielded power conductors for more than three (3) FCM 300 units.

NOTE:

It is the user's or installer's responsibility to ensure correct grounding and branch circuit protection in accordance with national and local codes.

The ground leakage currents are higher than 3.5 mA. This means the FCM 300 requires a fixed, permanent installation, as well as reinforced protective grounding.

To meet EMC specifications, control cables must be shielded. Connect the shielded cable to ground at both ends and use cable clamps.

Before wiring the unit, make sure your supply voltage corresponds with the voltage requirement of the FCM 300 unit, TT, IT and TN lines.

Type B RCD's (ELCB relays) or multiple protective grounding can be used as extra protection of 3 phase equipment with a bridge rectifier and for a brief discharge on power-up. If RCD's are used, local regulations must be observed.

Be sure the installation is fused correctly.

Connect the three AC line phases to terminals L1, L2 and L3 and the ground to the separate earth ground terminal provided. When power is applied, the green LED (LED 302) should be lit to indicate the power is on. In units with built-in Profibus, LED 303 will flash. For further information on Profibus, please see the Profibus manual.

For start-up instructions, please see "Operation" on page 7-2.

AC Line Fuses

- External fuses must be installed in the AC line supply to the FCM 300 unit.

FCM Type	AC Line Voltage	Bussmann KTS-R or JJS Type:
305	380-480 VAC	10 A
307	380-480 VAC	10 A
311	380-480 VAC	10 A
315	380-480 VAC	10 A
322	380-480 VAC	10 A
330	380-480 VAC	15 A
340	380-480 VAC	15 A
355	380-480 VAC	25 A
375	380-480 VAC	25 A

Suitable for use on a circuit capable of delivering not more than 100,000 rms Symmetrical Amperes, 500 Volts Maximum, when protected by the above fuses.

Chapter 7

- Start-up page 7-2

- Control Options page 7-2
 - Serial Communication page 7-2
 - VLT Dialog and PC page 7-3
 - Local Control Panel (LCP-2) page 7-3
 - Local Operation Pad (LOP) page 7-4

- Local Control Panel page 7-5
 - Display page 7-5
 - Control Keys page 7-6
 - Control Keys Functions page 7-6
 - Display Read-out State page 7-7
 - Display Mode page 7-7
 - Quick Menu Mode vs. Menu Mode page 7-8
 - Parameter Selection page 7-8
 - Menu Mode page 7-9
 - Parameter Groups page 7-9
 - Change Data page 7-9
 - Menu Structure page 7-11

Operation

■ Start-up

After AC line connections have been made, check to see that the LED 302 (green) is lit. For Profibus versions, LED 303 will flash. For more Profibus information, see the Profibus manual.

For out-of-the-box use without an LOP, LCP-2, serial communications or PC (see "Control Options"), simple on/off and speed control is accomplished as follows:

1. Run cable from terminals 4 and 6 to a start/stop contact or switch. See diagram below.
2. Wire potentiometer to terminals 2, 7 and 8. See diagram below.

NOTE:

Pre-programmed factory parameter settings are suitable for basic on/off and speed operation as depicted in the following diagram.

Connection diagram - factory setting

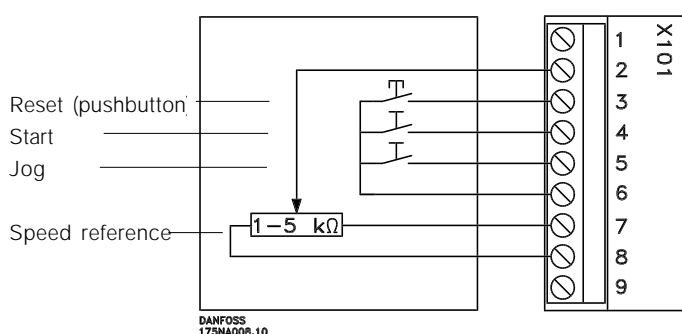

- *Reset* to be closed short time for resetting fault trips
- *Start* to be closed (maintained) for changing to *run mode*
- *Jog* will run at fixed speed while closed (10 Hz)
- *Speed reference* (0-10 V) determines speed while in *run mode*

NOTE:

Be sure the lid screws are tightened down sufficiently (19.5 - 21.2 lb-in) to seal lid.

NOTE:

The rotational direction of the motor can not be changed by switching phases. The default direction is clockwise. Changing the motor direction must be programmed in parameter 200.

■ Control Options

The FCM 300 can be programmed and operated with:

1. Serial communication using the RS 485 connection
2. VLT Dialog software and a PC using the RS 485 connection
3. Local Control Panel (LCP-2)

The FCM 300 can be operated, but not programmed with:

1. Local Operation Pad (LOP) wired to the control terminals

■ Serial Communication

Terminal block X100, terminals 1-4 are available for connecting an RS 485 bus.

■ **Serial Communication (continued...)**

For installations that require both serial communication and use of an LCP-2, the service plug kit (part #176NO166) and cable (part #175NO162) provides the necessary interface. The LCP-2 is attached to the cable and the RS 485 bus is connected to the X100 terminal strip.

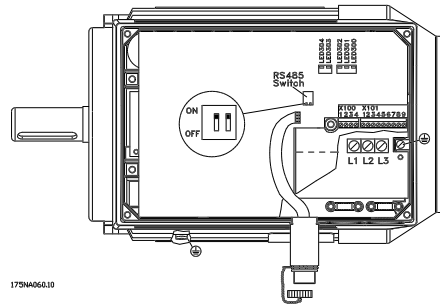

■ **VLT Dialog software and PC**

VLT Dialog is a powerful drive software tool that allows set-up, start-up and control of the FCM 300 and other Danfoss units.

Software only:	part #175ZO953
Software RS 232/485 converter and cables:	part #176F1705

Connect cables from PC to X 100 terminals.

NOTE:

The LCP-2 and VLT Dialog can not be used in conjunction with one another.

■ **Local Control Panel (LCP-2)**

The LCP-2 (part #175NO131) is used for programming and commissioning the FCM 300 units. Use the plug kit (part #175NO161) and cable (part #175NO162). The plug kit wires to the X100 terminals. See "Local Control" on page 7-5 for more information on the LCP-2.

When serial communication and the LCP-2 are to be used simultaneously, the service plug kit and cable provide an alternative connection for the LCP-2. For more information, see "Serial Communication" on this page.

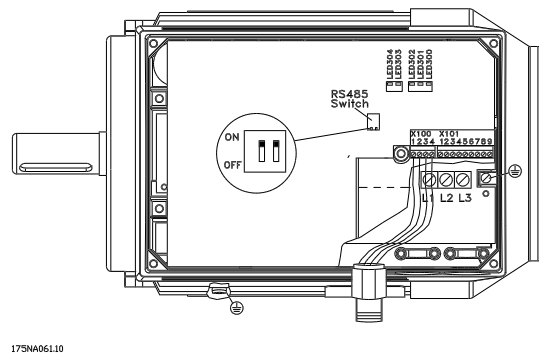

■ **Remote mounting kit**

A remote mounting kit (part #175NO160) is available to mount the LCP-2 on a wall or in a panel.

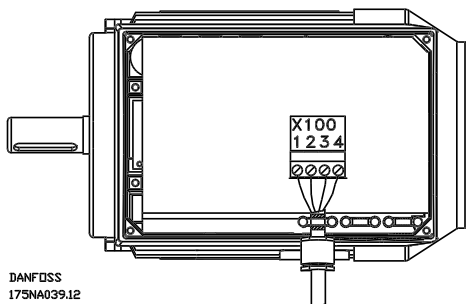

Color of wire/	Terminal X100/	D-sub pin
yellow	1	8
green	2	9
red	3	2
blue	4	3

Remote Mounting Kit continued...

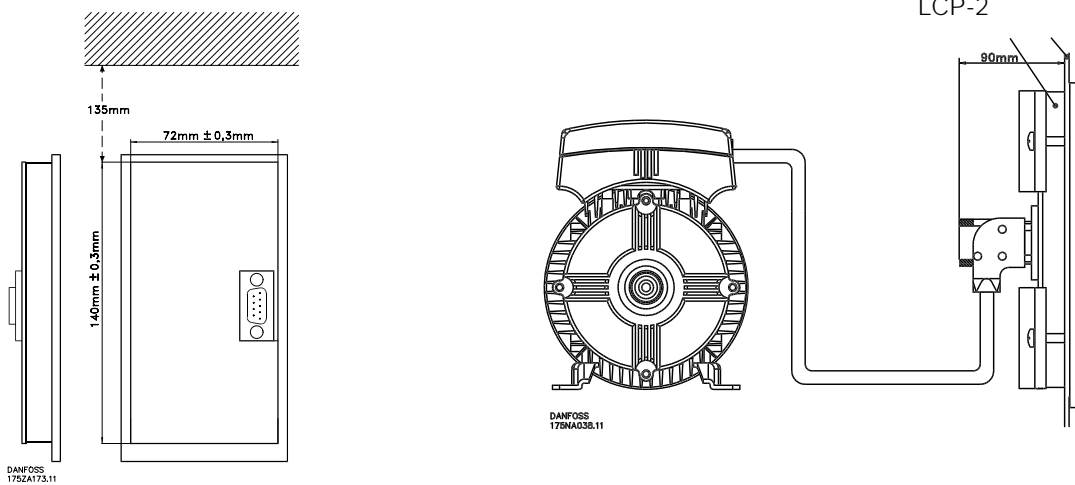

Local Operation Pad (LOP)

The LOP is wired directly to the X101 control terminals. The LOP provides speed control, a start/stop function and, depending on how it is wired and programmed, the following three functions:

1. Dual speed operation
2. Dual mode operation (Uses 2-Set-up Menus)
3. Dual direction operation (For forward or reverse)

NOTE!

After wiring the LOP, cut off or isolate any excess wire.

At power up the unit will always be in stop mode. Set reference will be stored during power down. If permanent start mode is desired, connect terminal 6 to terminal 4 and do not connect orange/gray wire to terminal 4. This means the stop function on LOP is disabled.

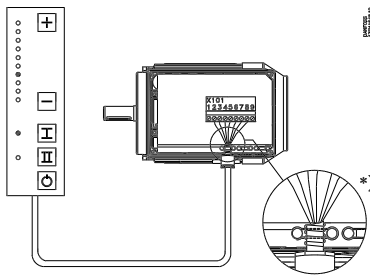

Wiring

Color of wire	Terminal	Function
White	2	Reference
Brown	3	Reset
Orange or Gray	4	See table under button I
Green	5	See table under button II
Red	6	+24V
Yellow	7	+10V
Blue	8	Ground

Function/settings	Key I (Start)	Key II (Start)	Key ⏻ (Stop)
Default - Dual speed operation (connect orange wire): No changes to factory setting.	Run on set reference (+/-)	Run on 10 Hz** jog speed	Stop (and reset* - if trip)
Function 2 - Dual mode operation (connect orange wire): Select desired modes of operation in Setups 1 and 2 (use para. 4-6) Parameter 335 = 18 (select Setup)	Run with Setup 1	Run with Setup 2	Stop (and reset* - if trip)
Function 3 - Dual direction operation (connect grey wire): Parameter 335 = 10 (start reversing) Parameter 200 = 1 (both directions)	Run forward	Run reverse	Stop (and reset* - if trip)

*If no reset is required, do not connect the brown wire

**or set parameter 213

Local Control

The LCP-2 is an optional control panel for programming and monitoring the FCM 300 unit.

NOTE:

The VLT 5000 Series LCP (part #175ZO401) can not be used with the FCM 300. However, the LCP-2 (part #175NO131) can be used with all VLT 5000, VLT 2800 and FCM 300 Series units.

LCP-2 installation

The LCP-2 is connected to the X100 terminals (1-4). For more information, see separate instruction manual MI.03.AX.YY.

LCP-2 Functions

The functions of the control panel can be divided into three groups:

- display
- keys for changing program parameters
- keys for local operation

All data is indicated by means of a 4-line alpha-numeric display, which in normal operation is able to show 4 measurements and 3 operating conditions continuously. During programming, all the information required for quick, effective parameter

Setup of the FCM 300 will be displayed. As a supplement to the display, there are three LEDs for voltage, warning and alarm.

All program parameters of the FCM 300 can be changed immediately from the control panel, unless this function has been blocked via parameter 018.

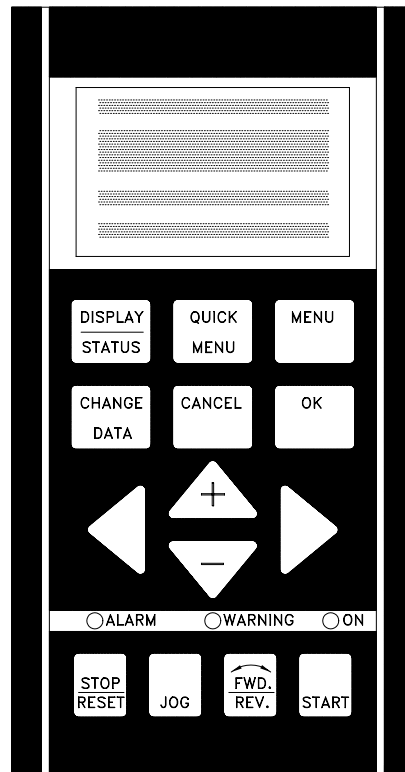

DANFOSS
175ZA004.10

Display

The LCD-display is back-lit with 4 alpha-numeric lines. The display also shows the direction of motor rotation with an arrow, the active set-up, and the set-up currently being programmed (can be different than the active set-up).

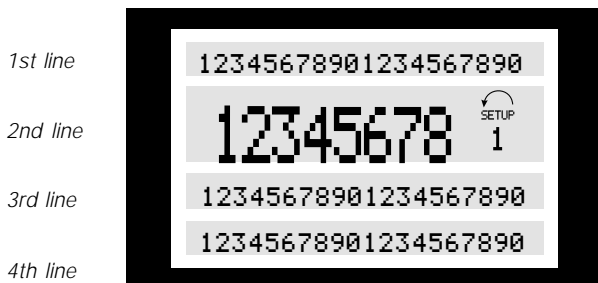

1st line shows up to 3 measurements continuously in normal operating status or a text which explains the 2nd line.

2nd line shows a measurement with related unit continuously, regardless of status (except in the case of alarm/warning).

3rd line is normally blank and is used in the menu mode to show the selected parameter number or parameter group number and name.

4th line is used in operating status for showing a status text or in data change mode for showing the value of the selected parameter.



An arrow indicates the direction of rotation of the motor. Furthermore, the Setup which has been selected as the Active Setup in parameter 004 is shown. When programming another Setup than the Active Setup, the number of the Setup which is being programmed will appear to the right. This second Setup number will flash.

LEDs

At the bottom of the control panel is a red alarm LED and a yellow warning LED, as well as a green voltage LED.

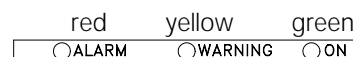

If certain threshold values are exceeded, the alarm and/or warning lamp is lit together with a status and alarm text on the control panel.

The green ON LED will be lit when power is applied to the FCM 300 unit and text will appear on the back-lit display.

■ Control Keys

The control keys above the line of LEDs are used for programming. Some parameters can be changed while the FCM 300 is operating.

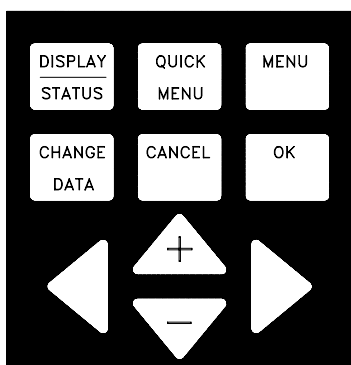

The four keys below the LED indicators are for local control of the FCM 300.

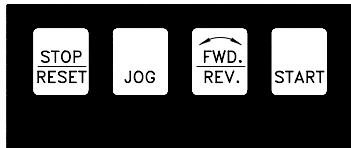

■ Control Key Functions



[DISPLAY / STATUS] is used for selecting the mode of display or for changing back to Display mode from either the Quick menu mode or the Menu mode.



[QUICK MENU] is used for programming the parameters that belong under the Quick menu mode. It is possible to switch directly between Quick menu mode and Menu mode.



[MENU] is used for programming all parameters. It is possible to switch directly between Menu mode and Quick menu mode.



[CHANGE DATA] is used for changing the parameter selected either in the Menu mode or the Quick menu mode.



[CANCEL] is used if a change of the selected parameter is not to be carried out.



[OK] is used for confirming a change of the parameter selected.



[+/-] is used for selecting parameter and for changing the chosen parameter or for changing the read out in line 2.

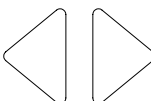

[<>] is used for selecting group and to move the cursor when changing numerical parameters.



[STOP / RESET] is used for stopping or for resetting the FCM 300 after a drop-out (trip). Can be selected via parameter 014 to be active or inactive. If stop is activated, line 2 will flash, and [START] must be activated.

NOTE!

Pressing [STOP/RESET] will prevent motor from running also with disconnected LCP-2.

Restarting is only possible via the LCP-2 [START] key.



[JOG] overrides the output frequency to a preset frequency while the key is kept down. Can be selected via parameter 015 to be active or inactive.



[FWD / REV] changes the direction of rotation of the motor, which is indicated by means of the arrow on the display although only in Local. Can be selected via parameter 016 to be active or inactive (parameter 013 must be set to [1] or [3] and parameter 200 set to [1]).



[START] is used for starting the FCM 300 after stop via the [Stop] key. Is always active, but cannot override a stop command given via the terminal strip.

NOTE:

Using factory settings, the local control keys (bottom 4 of the display) will be active in Local Control or Remote Control modes (parameter 002), except for [FWD/REV] which is only active in Local operation. All 4 local control keys can be disabled via parameters 014-017.

NOTE:

Care should be taken when disabling the [STOP] key! With no external stop function and parameter 014 disabled, the FCM 300 can be started, but stopped only by disconnecting power to the motor.

- Line 1 of the display lists 3 variables: 1.1, 1.2 and 1.3
- Line 2 gives the fourth variable (shown as VAR 2)
- Line 4 shows the present operating status or alarms and warnings.



■ **Display Read-out State**

The display read-out operating values can be changed via parameters 009-012. A list of selectable operating values follows:

Operating variable:	Unit:
Reference	[%]
Reference	[unit]*
Feedback	[unit]*
Frequency	[Hz]
Frequency x scaling	[-]
Motor current	[A]
Torque	[%]
Power	[kW]
Power	[HP]
Motor voltage	[V]
DC-link voltage	[V]
FC thermal	[%]
Hours run	[Hours]
Input status, dig. Input	[Binary code]
External reference	[%]
Status word	[Hex]
Heat sink temp.	[°C]
Alarm word	[Hex]
Control word	[Hex]
Warning word 1	[Hex]
Warning word 2	[Hex]
Analog input 1	[mA]
Analog input 2	[V]

*) Select in parameter 416. The unit is shown in readout state 1 line 1 otherwise 'U' is shown.

The number of variables to be viewed on the display is determined by the read-out state:

Read-out state:	I:	II:	III:
Line 1	Description for operating variable in line 2	Data value for 3 operating variables in line 1	Description for 3 operating variables in line 1

Read-out state 1:

This read-out state is standard after start-up or initializing the unit.

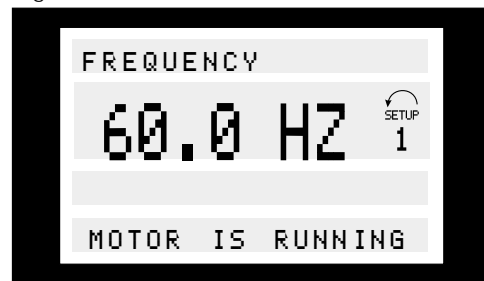

Line 2 provides the operating variable and Line 1 gives a text description of Line 2. The displayed variable of Line 2 is programmable via parameter 009. Or, the [+/-] keys scroll through the available variable selections during normal operation.

■ **Display Mode**

During normal operation, up to 4 different operating variables can be viewed simultaneously on the display. Each line of the display has a specific purpose:

Read-out state 2:

Press the [DISPLAY/STATUS] key once to activate read-out state 2. To return to state 1, push the [DISPLAY/STATUS] key again.

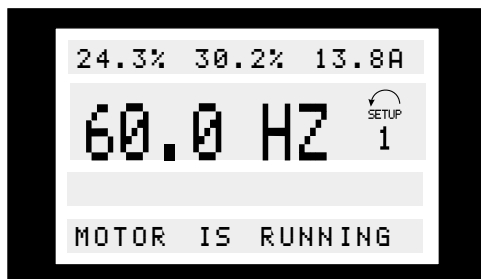

In this state, four operating values are shown at the same time. In the example, Reference, Torque, Current and Frequency are selected as variables in the first and second line.

Read-out state 3:

Continuously hold down the [DISPLAY/STATUS] key to activate read-out state 3. Releasing the [DISPLAY/STATUS] key switches the read-out to state 2. Push the [DISPLAY/STATUS] key once more to return to state 1.



This state shows the names of the operating variables that correspond to the values seen in state 2.

■ Quick Menu Mode vs. Menu Mode

The FCM 300 has many parameters to accommodate different applications. The Quick Menu contains the 10 most utilized parameters that are needed for programming in most applications. If the parameters in the Quick Menu do not give the desired functionality, use of the full Menu is always available.

NOTE:

Some parameters can be utilized in the Menu mode. For instance, if *Open Loop* is chosen in parameter 100, the PID parameters will be hidden.

The parameter names and corresponding numbers (EX Parameter 001 = Language, Parameter 200 = Direction of rotation) are the same in Quick Setup Menu and Menu modes.

Changing a parameter in one mode automatically changes the same parameter in the other mode.

■ Quick Setup via Quick Menu

Initiate the Quick Setup mode by pressing the [QUICK MENU] key once, which gives the following read-out display:



The 3rd Line gives the parameter number and name. The 4th Line shows the status/value of the parameter. After power-up, the Quick Menu will always start at Position 1 (See "Parameter Selection" below).

■ Parameter Selection

Scroll through the Quick Menu parameters by pressing the [+/-] keys. The parameters and their positions within the Quick Menu are as follows:

Pos.:No.:	Parameter:	Unit:
1 001	Language	
2 200	Direction of rotation	
3 101	Torque characteristic	
4 204	Min. reference	[Hz]
5 205	Max. reference	[Hz]
6 207	Ramp up time	[sec.]
7 208	Ramp down time	[sec.]
8 002	Local/remote control	
9 003	Local reference	
10 500	Bus address	

■ Menu Mode

Press the [MENU] key once to display the Menu mode. The display will look like this:

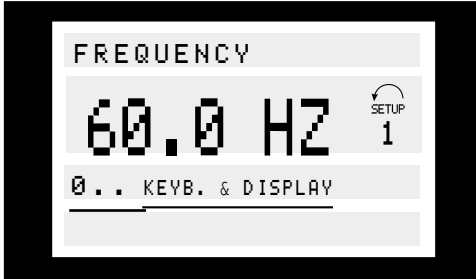

Line 3 of the display shows the parameter group number and name.

■ Parameter Groups

The Menu mode parameters are divided into groups. Scroll through the parameter group (0-6) by pressing the [<] or [>] keys. The parameter groups are as follows:

Group no.	Parameter group:
0	Operation & Display
1	Load & Motor
2	References & Limits
3	Inputs & Outputs
4	Special functions
5	Serial communication
6	Technical functions

*For information on parameter group 800 and 900 for PROFIBUS, please see the FCM Profibus manual MG.03.EX.YY.

When the desired parameter group is selected, push the [+] or [-] keys to obtain access to the individual parameters.

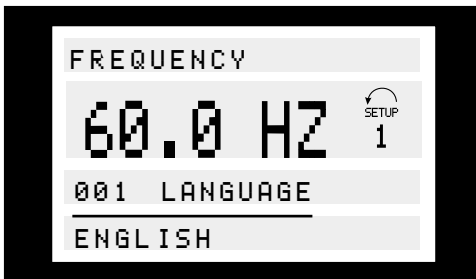

The 3rd Line of the display shows the parameter number and name, while the status/value of the selected parameter is shown in Line 4.

■ Change Data

Regardless of whether a parameter has been selected under the Quick Menu or Menu mode, the procedure for changing data remains the same. Pressing the [CHANGE DATA] key once will underline the status/value of the selected parameter in Line 4 and the text will flash. The next step for changing the data depends on whether the selected parameter represents a numerical data value or a text value.

■ Changing a Text Value

If the selected parameter is a text value, using the [+] or [-] keys after the [CHANGE DATA] key has been pressed will scroll through the possible text values for that parameter.



The 4th Line of the display shows the text value that will be entered (saved) when the data is accepted. To accept the data, push the [OK] key once.

■ **Infinitely variable change of numeric data value**

If the chosen parameter represents a numeric data value, the position (tens, tenths, hundreds, etc.) is chosen by scrolling with the [] or [] keys.



Pressing [] or [] keys changes the digit (0-9) of the selected position:

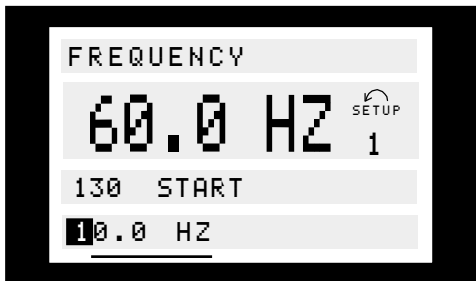

The digit in the position being altered with flash, when the 4th Line reads the desired value to be saved, press [OK] once.

■ Menu structure

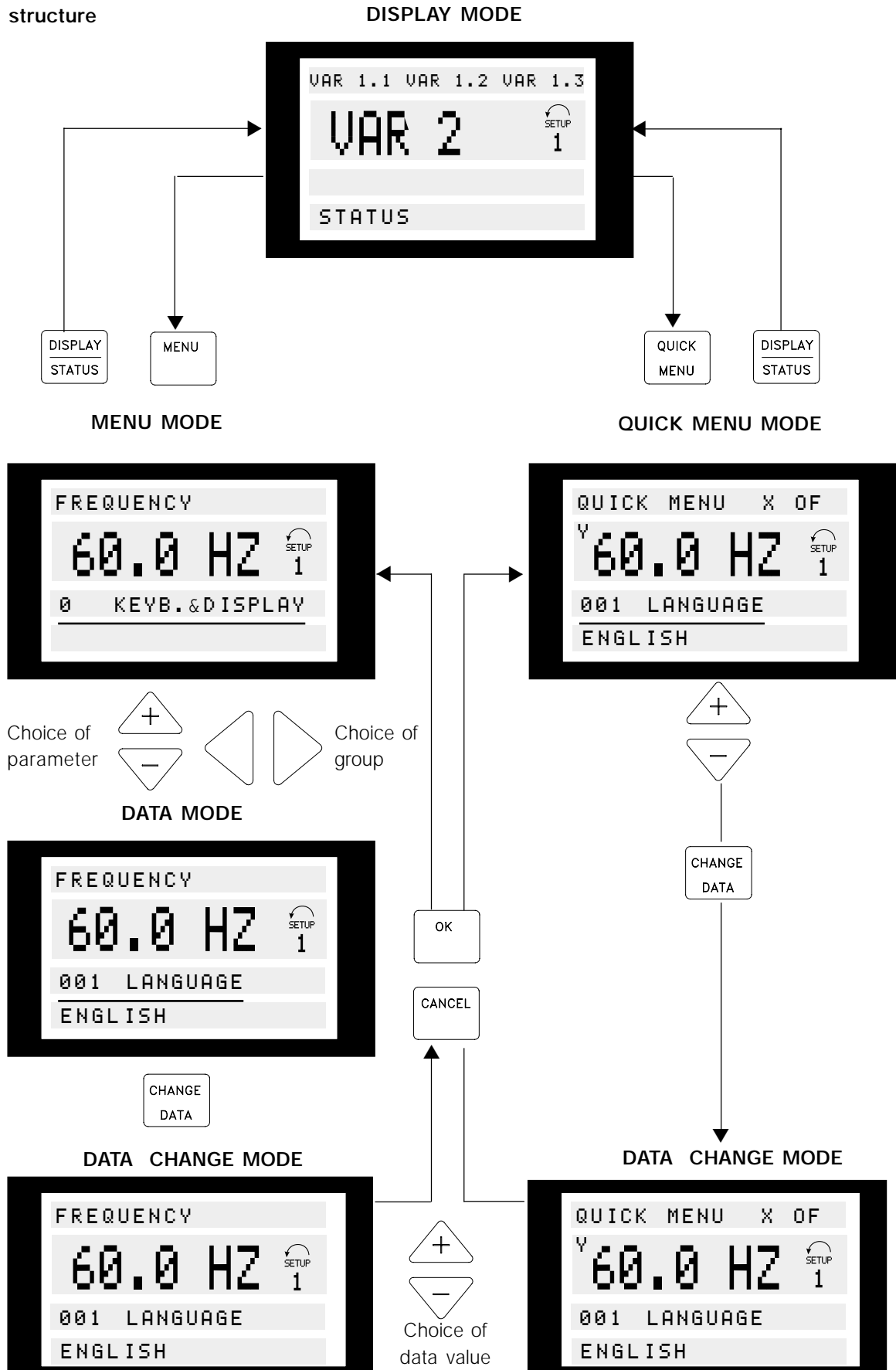



FCM 300 Series

Chapter 8

- Parameters 001-019 page 8-2
Operation and Display

How to Read the Parameter Settings

Before working with the parameter settings, it is important to note that there are various settings depending on the product.

The standard parameter settings (general factory settings) are marked with ★. These settings are listed in the back of this manual under "Standard Parameter Settings".

However, there are some special settings only applicable for HVAC and industrial products. Whereever these settings are applied, it is marked with "H" for HVAC products and "I" for industrial products. The settings differing from the standard parameter settings are also listed in the back of the manual.

NOTE! If **H** or **I** is not stated, the standard parameters settings are to be used.

001 Language	
(LANGUAGE)	
Settings:	
★ English (ENGLISH)	[0]
German (DEUTSCH)	[1]
French (FRANCAIS)	[2]
Danish (DANSK)	[3]
Spanish (ESPAÑOL)	[4]
Italian (ITALIANO)	[5]

State when delivered may vary from factory setting.

Function:
The choice in this parameter defines the language to be used on the display.

Description of choice:
There is a choice of *English* [0], *German* [1], *French* [2], *Danish* [3], *Spanish* [4] and *Italian* [5].

002 Local/remote control	
(OPERATION SITE)	
Settings:	
★ Remote control (REMOTE)	[0]
Local control (LOCAL)	[1]

Function:
There is a choice of two methods of controlling the FCM 300: *Remote control* [0] and *Local control* [1].

Description of choice:
If *Remote control* [0] is selected, the FCM 300 can be controlled via:

1. The control terminals or the serial communication port .
2. The [START] key. However, this cannot override Stop commands (also start-disable) entered via the digital inputs or the serial communication port.
3. The [STOP], [JOG] and [RESET] keys, provided that these are active (see parameters 014, 015 and 017).

If *Local control* [1] is selected, the FCM 300 can be controlled via:

1. The [START] key. However, this cannot override Stop commands on the digital terminals (if [2] or [4] has been selected in parameter 013).
2. The [STOP], [JOG] and [RESET] keys, provided that these are active (see parameters 014, 015 and 017).
3. The [FWD/REV] key, provided that this has been activated in parameter 016 and that in parameter 013 a choice of [1] or [3] has been made.
4. Via parameter 003 the local reference can be controlled by means of the " []" and " []" keys.

★ = General factory setting - also applying to spare part unit, **H** = HVAC setting, **I** = Industrial setting, () = display text [] = value for use in communication via serial communication port

FCM 300 Series

Setups 1 [1] and 2 [2] are individual Setups which can be used as required. They can be programmed freely, regardless of the Setup selected as the Active Setup and thus controlling the functions of the FCM 300.

NOTE!

If a general change of data or a copying to the Active Setup is effected, this immediately affects the functioning of the unit.

006 Copying of Setups (SETUP COPY)

Settings:

- ★ No copying (NO COPY) [0]
- Copy to Setup 1 from # (COPY TO SETUP 1) [1]
- Copy to Setup 2 from # (COPY TO SETUP 2) [2]
- Copy to Setup all from # (COPY TO ALL) [5]

= the Setup selected in parameter 005

Function:

A copy is made from the Setup selected in parameter 005 to one of the other Setups or to all the other Setups simultaneously.

NOTE!

Copying is only possible in Stop Mode (motor stopped on a Stop command).

Copying will take max. 3 seconds and has ended when parameter 006 has returned to value 0.

007 LCP copy (LCP COPY)

Settings:

- ★ No copying (NO COPY) [0]
- Upload all parameters (UPLOAD ALL PARAM) [1]
- Download all parameters (DOWNLOAD ALL) [2]
- Download power-independent par. (DOWNLOAD SIZE INDEP.) [3]

Function:

Parameter 007 is used if it is desired to use the integrated copying function of the control panel. You can therefore easily copy parameter value(s) from one FCM 300 to another.

★ = General factory setting - also applying to spare part unit, **H** = HVAC setting, **I** = Industrial setting, () = display text [] = value for use in communication via serial communication port

Description of choice:

Select *Upload all parameters* [1] if all parameter values are to be transmitted to the control panel. Select *Download all parameters* [2] if all transmitted parameter values are to be copied to the FCM 300 on which the control panel has been mounted. Select *Download power-independent par.* [3] if only the power-independent parameters are to be downloaded. This is used if downloading to a FCM 300 that has a different rated power than the one from where the parameter Setup originates.

NOTE!

Uploading/Downloading can only be carried out in the Stop mode and only between units with the same database version (see par. 626 value)

008 Display scaling of motor frequency (FREQUENCY SCALE)

Settings:

- 0.01 - 100.00 [- 10000]
- ★ 1.00 [100]

Function:

This parameter chooses the factor to be multiplied by the motor frequency, f_M , for presentation in the display, when parameters 009-012 have been set for Frequency x Scaling [5].

Description of choice:

Set the desired scaling factor.

009 Display line 2 (DISPLAY LINE 2)

Settings:

- None [0]
- Reference [%] (REFERENCE [%]) [1]
- Reference [unit] (REFERENCE [UNIT]) [2]
- Feedback [unit] (FEEDBACK [UNIT]) [3]
- ★ Frequency [Hz] (FREQUENCY [Hz]) [4]
- Frequency x Scaling [-] (FREQUENCY X SCALE) [5]
- Motor current [A] (MOTOR CURRENT [A]) [6]
- Torque [%] (TORQUE [%]) [7]
- Power [kW] (POWER [kW]) [8]
- Power [HP] (POWER [hp] [US]) [9]
- Motor voltage [V] (MOTOR VOLTAGE [V]) [11]

FCM 300 Series

DC link voltage [V] (DC LINK VOLTAGE [V])	[12]
Thermal load, FC [%] (FC THERMAL [%])	[14]
Hours run [Hours] (RUNNING HOURS)	[15]
Digital input [Binary code] (DIGITAL INPUT [BIN])	[16]
External reference [%] (EXTERNAL REF [%])	[21]
Status word [Hex] (STATUS WORD [HEX])	[22]
Heat sink temp. [°C] (HEATSINK TEMP [°C])	[25]
Alarm word [Hex] (ALARM WORD [HEX])	[26]
Control word [Hex] (CONTROL WORD [HEX])	[27]
Warning word 1 [Hex] (WARNING WORD 1 [HEX])	[28]
Warning word 2 [Hex] (WARNING WORD 2 [HEX])	[29]
Analog input 1 [mA] (ANALOG INPUT 1 [mA])	[30]
Analog input 2 [V] (ANALOG INPUT 2 [V])	[31]

Function:

This parameter allows a choice of the data value to be displayed in line 2 of the display. Parameters 010-012 enable the use of three additional data values to be displayed in line 1.

NOTE!

In parameter 009, "none" [0] cannot be selected.

Description of choice:

Reference [%] corresponds to the total reference (sum of digital/analog/preset/bus/freeze ref./catch-up and slow-down).

Reference [unit] gives the sum of the references using the unit stated on the basis of configuration in parameter 100 (Hz, Hz and rpm).

Feedback [unit] gives the status value of terminal 1 and 2 using the unit/scale selected in parameter 414, 415 and 416.

Frequency [Hz] gives the motor frequency, i.e. the output frequency to the motor.

Frequency x Scaling [-] corresponds to the present motor frequency f_M multiplied by a factor (scaling) set in parameter 008.

Motor current [A] states the phase current of the motor measured as effective value.

Torque [%] gives the current motor load in relation to the rated motor torque.

Power [kW] states the actual power consumed by the motor in kW.

Power [HP] states the actual power consumed by the motor in HP.

★ = General factory setting - also applying to spare part unit, **H** = HVAC setting, **I** = Industrial setting, () = display text [] = value for use in communication via serial communication port

Motor voltage [V] states the voltage supplied to the motor.

DC link voltage [V] states the intermediate circuit voltage in the FCM 300.

Thermal load, FC [%] states the calculated/estimated thermal load on the FCM 300. 100% is the cut-out limit.

Hours run [Hours] states the number of hours that the motor has run since the latest reset in parameter 619.

Digital input [Binary code] states the signal states from the 4 digital terminals (2, 3, 4 and 5). Input 5 corresponds to the bit at the far left. '0' = no signal, '1' = connected signal.

External reference [%] gives the sum of the external reference as a percentage (the sum of analog/pulse/bus).

Status word [Hex] gives the status word sent via the serial communication port in Hex code from the FCM 300.

Heat sink temp. [°C] states the present heat sink temperature of the FCM 300. The cut-out limit is $90 \pm 5^\circ\text{C}$; cutting back in occurs at $60 \pm 5^\circ\text{C}$.

Alarm word [Hex] indicates one or several alarms in a Hex code.

Control word. [Hex] indicates the control word for the FC motor. See *Serial communication*.

Warning word 1. [Hex] indicates one or more warnings in a Hex code.

Warning word 2. [Hex] indicates one or more status states in a Hex code.

Analog input 1 [mA], states the signal value on terminal 1.

Analog input 2 [V], states the signal value on terminal 2.

010 Display line 1.1 (DISPLAY LINE 1.1)

Value:

★ Reference [%] [1]

See parameter 009.

Function:

This parameter enables a choice of the first of three data values to be shown on the display, line 1, position 1.

For display read-outs, press the [DISPLAY/STATUS] button.

FCM 300 Series

Description of choice:
 There is a choice of 24 different data values, see parameter 009.

- LCP control/as parameter 100.
 (LCP CTRL/AS P100) [3]
 ★ LCP digital control/as parameter 100.
 (LCP+DIG CTRL/AS P100) [4]

011 Display line 1.2 (DISPLAY LINE 1.2)

Value:
 ★ Motor current [A] [6]

See parameter 009

Function:

This parameter enables a choice of the second of the three data values to be shown on the display, line 1, position 2.
 For Display read-outs, press the [DISPLAY/STATUS] button.

Function:

This is where the desired function is to be selected if Local control has been chosen in parameter 002.
 See also the description of parameter 100.

Description of choice:

There is a choice of 24 different data values, see parameter 009.

Description of choice:

If *Local not active* [0] is selected, a possible setting of *Local reference via parameter* 003 is blocked. It is only possible to change to *Local not active* [0] from one of the other setting options in parameter 013, when the FCM 300 has been set to *Remote control* [0] in parameter 002.

LCP control and open loop [1] is used when the speed is to be adjustable (in Hz) via parameter 003, when the FCM 300 has been set to *Local control* [1] in parameter 002.

012 Display line 1.3 (DISPLAY LINE 1.3)

Value:
H,I Power [HP] [9]
 ★ Power [kW] [8]

See parameter 009

Function:

This parameter enables a choice of the third of the three data values to be shown on the display, line 1, position 3.
 Display read-outs are made by pressing the [DISPLAY/STATUS] button.

If parameter 100 has not been set to *Speed regulation open loop* [0], switch to *Speed regulation open loop* [0].

LCP digital control and open loop [2] functions as *LCP control and open loop* [1], the only difference being that when parameter 002 has been set to *Local operation* [1], the motor is controlled via the digital inputs.

LCP control/as parameter 100 [3] is selected if the reference is to be set via parameter 003.

Description of choice:

There is a choice of 24 different data values, see parameter 009.

LCP digital control/as parameter 100 [4] functions as *LCP control/as parameter 100* [3], although, when parameter 002 has been set to *Local operation* [1], the motor may be controlled via the digital inputs.

013 Local Control/Configuration as parameter 100 (LOCAL CTRL/CONFIG.)

Value:
 Local not active (DISABLE) [0]
 LCP control and open loop.
 (LCP CTRL/OPEN LOOP) [1]
 LCP digital control and open loop.
 (LCP+DIG CTRL/OP.LOOP) [2]

NOTE!

Shift from *Remote control* to *LCP digital control and open loop*:

The present motor frequency and direction of rotation must be maintained. If the present direction of rotation does not correspond to the reversing signal (negative reference), the motor frequency f_M will be set at 0 Hz.

★ = General factory setting - also applying to spare part unit, **H** = HVAC setting, **I** = Industrial setting,
 () = display text [] = value for use in communication via serial communication

FCM 300 Series

Shift from *LCP digital control and open loop to Remote control*:

The selected configuration (parameter 100) will be active. Shifts are effected without any abrupt movement.

Shift from *Remote control to LCP control/as parameter 100 or LCP digital control/as parameter 100*.

The present reference will be maintained. If the reference signal is negative, the local reference will be set at 0.

Shift from *LCP control/as parameter 100 or LCP remote control as parameter 100 to Remote control*.

The reference will be replaced by the active reference signal from the remote control.

014 Local stop (LOCAL STOP)

Value:

- | | |
|------------------------|-----|
| Not possible (DISABLE) | [0] |
| ★ Possible (ENABLE) | [1] |

Function:

This parameter disables/enables the local stop function in question from the control panel. This key is used when parameter 002 has been set for *Remote control* [0] or *Local* [1].

Description of choice:

If *Disable* [0] is selected in this parameter, the [STOP] key will be inactive.

NOTE!

If *Enable* is selected, the [STOP] key overrides all Start commands.

015 Local jog (LOCAL JOGGING)

Value:

- | | |
|--------------------------|-----|
| ★ Not possible (DISABLE) | [0] |
| Possible (ENABLE) | [1] |

Function:

In this parameter, the jog function can be enabled/disabled on the control panel.

Description of choice:

If *Disable* [0] is selected in this parameter, the [JOG] key will be inactive.

016 Local reversing

(LOCAL REVERSING)

Value:

- | | |
|--------------------------|-----|
| ★ Not possible (DISABLE) | [0] |
| Possible (ENABLE) | [1] |

Function:

In this parameter, the reversing function can be enabled/disabled on the control panel. This key can only be used if parameter 002 has been set to *Local operation* [1] and parameter 013 to *LCP control with open loop* [1] or *LCP control as parameter 100* [3].

Description of choice:

If *Disable* [0] is selected in this parameter, the [FWD/REV] key will be inactive. See parameter 200.

017 Local reset of trip (LOCAL RESET)

Value:

- | | |
|------------------------|-----|
| Not possible (DISABLE) | [0] |
| ★ Possible (ENABLE) | [1] |

Function:

In this parameter, the reset function can be selected/removed from the keyboard. This key can be used when parameter 002 has been set for *Remote control* [0] or *Local control* [1].

Description of choice:

If *Disable* [0] is selected in this parameter, the [RESET] key will be inactive.

NOTE!

Only select *Disable* [0] if an external reset signal has been connected via the digital inputs.

★ = General factory setting - also applying to spare part unit, **H** = HVAC setting, **I** = Industrial setting, () = display text [] = value for use in communication via serial communication port

FCM 300 Series
018 Lock for data change
(DATA CHANGE LOCK)

Value:

- | | |
|---------------------------|-----|
| ★ Not locked (NOT LOCKED) | [0] |
| Locked (LOCKED) | [1] |

Function:

In this parameter, the software can "lock" the control, which means that data changes cannot be made via LCP 2 (however, this is still possible via the serial communication port).

Description of choice:

If *Locked* [1] is selected, data changes cannot be made.

019 Operating state at power up, local
control (POWER UP ACTION)

Value:

- | | |
|---|-----|
| H Auto restart, use saved ref.(AUTO RESTART) | [0] |
| ★ Forced stop, use saved ref. (LOCAL=STOP) | [1] |
| Forced stop, set ref. to 0
(LOCAL=STOP, REF=0) | [2] |

Function:

Setting of the desired operating mode when the mains voltage is reconnected.

This function can only be active in connection with *Local control* [1] in parameter 002.

Description of choice:

Auto restart, use saved ref. [0] is selected if the unit is to start up with the same local reference (set in parameter 003) and the same start/stop conditions (given via the [START/STOP] keys) that the FCM 300 had before it was switched off.

Forced stop, use saved ref. [1] is used if the unit is to remain stopped when the mains voltage is connected, until the [START] key is pressed. After the start command, the local reference used is set in parameter 003.

Forced stop, set ref. to 0 [2] is selected if the unit is to remain stopped when the mains voltage is connected. Local reference (parameter 003) is reset.

NOTE!

In remote controlled operation (parameter 002), the start/stop condition at power up will depend on the external control signals. If *Latched start* is selected in parameter 332-335, the motor will remain stopped at power up.

★ = General factory setting - also applying to spare part unit, H = HVAC setting, I = industrial setting,
() = display text [] = value for use in communication via serial communication port



FCM 300 Series

Chapter 9

- Parameters 100-139 page 9-2
Load and motor

100 Configuration (CONFIG. MODE)

Settings:

- ★ Speed, open loop mode (SPEED OPEN LOOP) [0]
Process, closed loop mode (PROCESS CLOSED LOOP) [3]

Function:

This parameter is used for selecting the configuration to which the FCM 300 is to be adapted.

Description of choice:

If *Speed, open loop mode* [0] is selected, a normal speed control (without feedback signal) is obtained, but with automatic slip compensation, ensuring a nearly constant speed at varying loads. Compensations are active, but may be disabled as required in parameter 133 - 136.

If *Process, closed loop mode* [3] is selected, the internal process regulator will be activated, thereby enabling accurate regulation of a process with respect to a given process signal. The process signal can be set using the actual process unit or as a percentage. A feedback signal must be supplied from the process, and the process setpoint must be adjusted. In process closed loop both directions is not allowed in parameter 200.

NOTE!

This is only possible in Stop Mode (motor stopped on a Stop command).

101 Torque characteristics (TORQUE CHARACT)

Settings:

- H Variable torque: high (VAR.TORQUE: HIGH) [4]
- ★ Constant torque (CONSTANT TORQUE) [1]
Variable torque: low (VAR.TORQUE: LOW) [2]
Var. torque: medium (VAR.TORQUE: MEDIUM) [3]

Function:

In this parameter, the principle for adjusting the U/f characteristics of the FCM 300 to the torque characteristics of the load is selected.

Description of choice:

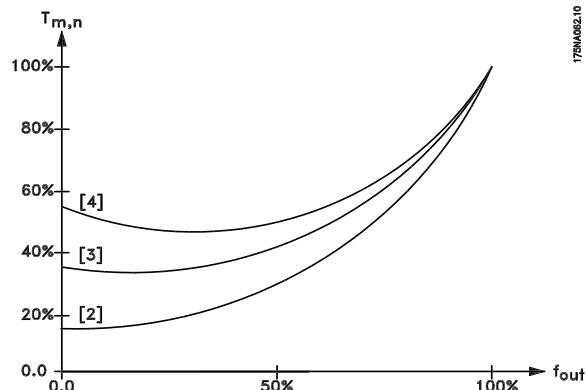

If *Constant torque* [1] is selected, a load-dependent U/f characteristic is obtained in which the output voltage is increased in the case of an increasing load (current) so as to maintain constant magnetization of the motor.

Select *Variable torque low* [2], *Variable torque medium* [3] or *Variable torque high* [4] if the load follows the square law (centrifugal pumps, fans).

NOTE!

Slip compensation (parameter 136) and start (parameter 134) are not active if a variable torque is used.

102 Motor power (MOTOR POWER)

Value:

XX.XX kW - depends on the FCM 300 [XXXX]

Function:

Read only parameter.

103 Motor voltage (MOTOR VOLTAGE)

Value:

XX V- depends on the FCM 300 [XX]

Function:

Read only parameter.

104 Motor frequency (MOTOR FREQUENCY)

Value:

XX.X Hz - depends on the FCM 300 [XXX]

★ = General factory setting - also applying to spare part unit, H = HVAC setting, I = Industrial setting, () = parameter window text. [] = value for use in communication via serial communication port

FCM 300 Series

Function:
Read only parameter.

105 Motor current (MOTOR CURRENT)
Value:
XX.X X A- depends on the FCM 300 [XXXX]

Function:
Read only parameter.

106 Rated motor speed (MOTOR NOM. SPEED)
Value:
XX rpm - depends on the FCM 300 [XX]

Function:
Read only parameter.

126 DC braking time (DC BRAKING TIME)
Settings:
0.0 - 60.0 sec. [0-600]
★ 10.0 sec. [100]

Function:
This parameter is for setting the DC braking time for which the DC braking voltage (parameter 132) is to be active.

0.0 sec. = OFF

Description of choice:
Set the desired time.

127 DC brake cut-in frequency (DC BRAKE CUT-IN)
Settings:
0.0 - f_{MAX} (parameter 202) [0 -]
★ 0.0 Hz = OFF [0]

Function:
This parameter is for setting the DC brake cut-in frequency at which the DC braking voltage (parameter 132) is to be active, in connection with a Stop command.

Description of choice:
Set the desired frequency.

128 Motor thermal protection (MOTOR THERM. PRO)
Settings:
★ Disable (DISABLE) [0]
Enable (ENABLE) [1]

Function:
The motor temperature is measured with a thermistor (optional).

Description of choice:
If *Disable* [0] is selected no tripping is required when the motor is overloaded.

132 DC braking voltage (DC BRAKE VOLTAGE)
Settings:
0 - 100 % [0-100]
★ 0 % [0]

Function:
If the stator in an asynchronous motor is supplied with DC voltage, a braking torque will occur. The braking torque depends on the selected DC braking voltage. The DC braking voltage is stated as a percentage of maximum braking voltage.

Description of choice:
Set the desired voltage as a specified percentage of maximum braking voltage.

NOTE!
The DC braking voltage cannot be used as a holding brake.

★ = General factory setting - also applying to spare part unit, **H** = HVAC setting, **I** = Industrial setting, () = parameter window text. [] = value for use in communication via serial communication port

133 Start voltage (START VOLTAGE)

Settings:
 0.00 - 100.00 V [0-10000]
 ★ Depends on motor

Function:
 You can set the motor voltage below the field weakening point independently of the motor current. Use this parameter to compensate for too low of starting torque.

The start voltage is the voltage at 0 Hz.

NOTE!
 If the start voltage is set too high, it can lead to magnetic saturation and motor overheating; the FCM 300 may trip. Therefore take care when using the start voltage.

Description of choice:
 Set the desired start voltage.

134 Start compensation (START COMP.)

Settings:
 0.0 - 300.0 % [0-3000]
 ★ 100.0 % [1000]

Function:
 The output voltage is compensated as a function of the load.

NOTE!
 If the value is too high the FCM 300 can trip due to overcurrent.

Description of choice:
 Enter a % value.
 Rated start compensation = 100 %.

135 U/f ratio (U/F RATIO)

Settings:
 0.00 - 20.00 V/Hz [0-2000]
 ★ Motor dependent

Function:
 The output voltage to the motor can be adjusted on a linear basis from 0 to rated frequency.

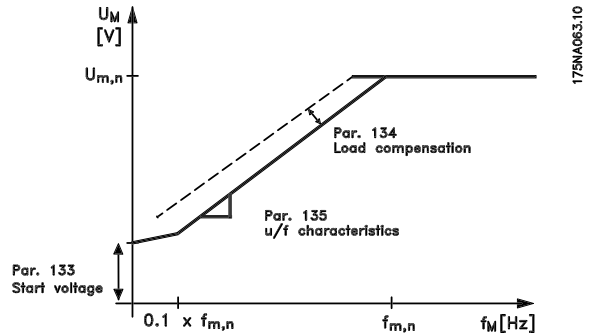

136 Slip compensation (SLIP COMP.)

Settings:
 500.0 - +500.0 % [-5000 - +5000]
 H 0% [0]
 ★ 100.0 % [1000]

Function:
 The rated slip compensation (factory setting) is calculated on the basis of the motor parameters. In parameter 136 the slip compensation can be adjusted in detail. Optimizing makes the motor speed less load dependent. This function is not active at the same time as variable torque (parameter 101).

Description of choice:
 Enter a % value of rated slip compensation.

★ = General factory setting - also applying to spare part unit, H = HVAC setting, I = Industrial setting, () = parameter window text. [] = value for use in communication via serial communication port

FCM 300 Series

137 DC holding voltage

(DC HOLD VOLTAGE)

Settings:

0 - 100 % [0-100]

★ 0 (OFF) % [0]

Function:

This parameter is used to uphold the motor function (holding torque) or to pre-heat the motor. DC holding voltage is active at stopped motor when it is set at a value which is different from 0. Coasting stop will deactivate the function.

Description of choice:

Enter a percentage value.

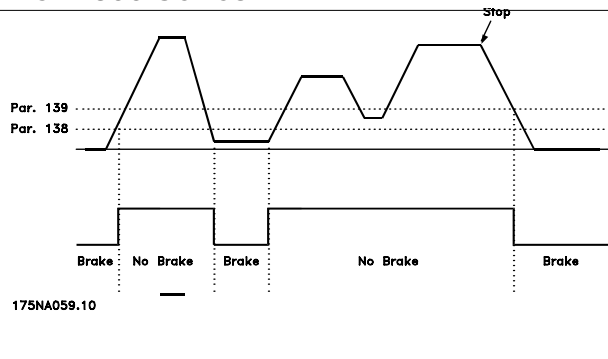

138 Brake cut out frequency

(BRAKE CUT OUT)

Settings:

0.5 - 132 Hz (parameter 200) [5-]

★ 3.0 Hz [30]

Function:

Here the frequency at which the external brake is to be released is selected via output set in parameter 340 during running.

Description of choice:

Set desired frequency.

139 Brake cut in frequency

(BRAKE CUT IN)

Settings:

0.5 - 132 Hz (parameter 200) [5-]

★ 3.0 Hz [30]

Function:

Here the frequency at which the external brake is to be activated is selected via output set in parameter 340 when the motor is ramping down to stop.

Description of choice:

Set the desired frequency.

★ = General factory setting - also applying to spare part unit, **H** = HVAC setting, **I** = Industrial setting, () = parameter window text. [] = value for use in communication via serial communication port



FCM 300 Series

Chapter 10

- Parameters 200-231 page 10-2
References and limits

FCM 300 Series

200 Rotation direction (ROTATION)

Settings:

- ★ Only clockwise,
0-132 Hz (132 Hz CLOCK WISE) [0]
- Both directions,
0-132 Hz (132 Hz BOTH DIRECTIONS) [1]
- Only counterclockwise, 0-132 Hz
(132Hz COUNTERCLOCKW.) [2]

Function:

This parameter guarantees protection against unwanted reversing.

Using *Process, closed loop* mode (parameter 100) parameter 200 must not be changed to *Both directions* [1].

Description of choice:

Select the desired direction seen from the motor drive end.

Note that if *Only clockwise, 0-132 Hz* [0]/*Only counterclockwise, 0-132 Hz* [2] is selected, the output frequency will be limited to the range f_{MIN} - f_{MAX} .

If *Both directions, 0-132 Hz* [1] is selected, the output frequency will be limited to the range $\pm f_{\text{MAX}}$ (the minimum frequency is of no significance).

NOTE!

This is only possible in Stop Mode (motor stopped on a Stop command).

201 Min. output frequency (MIN OUTPUT FREQ)

Settings:

- 0.0 Hz - f_{MAX} (parameter 202) [0 -]
- ★ 0.0 Hz [0]
- H 6.0 Hz [60]

Function:

In this parameter, a minimum motor frequency limit can be selected that corresponds to the minimum frequency at which the motor is to run.

The minimum frequency can never be higher than the maximum frequency, f_{MAX} .

If *Both directions* has been selected in parameter 200, the minimum frequency is of no significance.

Description of choice:

A value from 0.0 Hz to the max. frequency selected in parameter 202 (f_{MAX}) can be chosen.

202 Max. output frequency (MAX OUTPUT FREQ)

Settings:

- f_{MIN} (parameter 201) - f_{RANGE} (132 Hz, par. 200)
- ★ f_{RANGE}

Function:

In this parameter, a maximum motor frequency can be selected that corresponds to the highest frequency at which the motor is to run.

See also parameter 205.

Description of choice:

A value from f_{MIN} to 132 Hz can be selected.

203 Reference/feedback range (REF/FEEDB. RANGE)

Settings:

- ★ Min - Max (MIN - MAX) [0]
- Max - + Max (-MAX-+MAX) [1]

Function:

This parameter decides whether the reference signal is to be positive or can be both positive and negative.

NOTE!

Analogue input (reference/feedback) can only be positive.

Choose *Min - Max* [0] if *Process, closed loop mode* has been selected in parameter 100.

★ = General factory setting - also applying to spare part unit, H = HVAC setting, I = Industrial setting, () = parameter window text. [] = value for use in communication via serial communication port

FCM 300 Series
Description of choice:

Choose the desired range.

204 Minimum reference (MIN. REFERENCE)

Settings:
 -100,000.000 - Ref_{MAX} (par. 205) [-100000000 -]
H 60.000 [60]
 ★ 0.000 [0]

Function:

 The *Minimum reference* gives the minimum setting that can be assumed by the sum of all references.

Minimum reference is only active if *Min - Max* [0] has been set in parameter 203; however, it is always active in *Process, closed loop mode* (parameter 100).

Description of choice:

 Is only active when parameter 203 has been set to *Min - Max* [0].

Set the desired value.

205 Maximum reference (MAX. REFERENCE)

Settings:
 Ref_{MIN} (parameter 204)-100,000,000 [-1000000000]
H,I 60.000 Hz [60000]
 ★ 50.000 Hz [50000]

Function:

The *Maximum reference* gives the highest value that can be assumed by the sum of all references. If parameter 100 has been selected to open loop the max. setting is 132 Hz. If closed loop has been selected the maximum reference cannot be set higher than the maximum feedback (parameter 415).

Description of choice:

Set the desired value.

207 Ramp-up time (RAMP UP TIME)

Settings:
 0.15 - 3600.00 sec. [5 -360000]
H 60.00 sec. [6000]
 ★ 3.00 sec. [300]

Function:

The ramp-up time is the acceleration time from 0 Hz to the rated motor frequency $f_{M,N}$ (parameter 104). This assumes that the current limit is not reached (to be set in parameter 221).

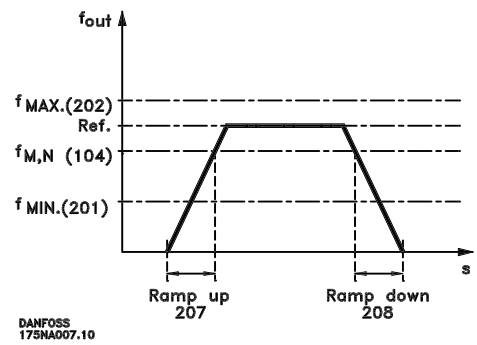
Description of choice:

Program the desired ramp-up time.

208 Ramp-down time (RAMP DOWN TIME)

Settings:
 0.15 - 3600.00 sec. [5 - 360000]
H 60.00 sec. [6000]
 ★ 3.00 sec. [300]

Function:

The ramp-down time is the deceleration time from the rated motor frequency $f_{M,N}$ (parameter 104) to 0 Hz provided there is no over-voltage in the inverter because of regenerative operation of the motor, and the current limit is not reached (to be set in parameter 221).

Description of choice:

Program the desired ramp-down time.

★ = General factory setting - also applying to spare part unit, **H** = HVAC setting, **I** = Industrial setting, () = parameter window text. [] = value for use in communication via serial communication port

211 Jog ramp time (JOG RAMP TIME)
Settings:

0.15 - 3600.00 sec. [5 - 360000]
H 60.00 sec. [6000]
 ★ 3.00 sec. [300]

Function:

The jog ramp time is the acceleration/deceleration time from 0 Hz to the rated motor frequency $f_{M,N}$ (parameter 104), provided there is no over-voltage in the inverter because of regenerative operation of the motor, and the current limit is not reached (to be set in parameter 221).

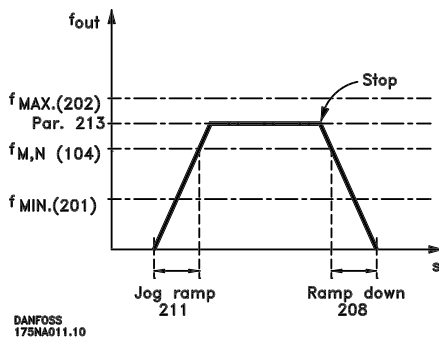

The jog ramp time starts if a jog signal is given via the digital inputs or the serial communication port.

Description of choice:

Set the desired ramp time.

212 Quick stop ramp-down time (Q STOP RAMP TIME)
Settings:

0.15 - 3600.00 sec. [5 - 360000]
 ★ 3.00 sec. [300]

Function:

The ramp-down time is the deceleration time from the rated motor frequency to 0 Hz, provided there is no over-voltage in the inverter because of regenerative operation of the motor, and the current limit is not reached (to be set in parameter 221).

Quick-stop is activated by means of a signal on one of the digital input terminals (2-5), or via the serial communication port.

FCM 300 Series
Description of choice:

Program the desired ramp-down time.

213 Jog frequency (JOG FREQUENCY)
Settings:

0.0 Hz - parameter 202 [0 -]
 ★ 10.0 Hz [100]

Function:

The jog frequency f_{JOG} is the fixed output frequency at which the FCM 300 is running when the jog function is activated.

Description of choice:

Set the desired frequency.

214 Reference function (REF FUNCTION)
Settings:

H External/preset (EXTERNAL/PRESET) [2]
 ★ Sum (SUM) [0]

Function:

It is possible to define how the preset references are to be added to the other references. For this purpose, *Sum* is used. It is also possible - by using the *External/preset* function - to select whether a shift between external references and preset references is desired.

Description of choice:

If *Sum* [0] is selected, one of the adjusted preset references (parameters 215-216) is added as a percentage of the maximum possible reference.

If *External/preset* [2] is selected, it is possible to shift between external references or preset references via terminal 2, 3, 4, or 5 (parameter 332, 333, 334, or 335). Preset references will be a percentage value of the reference range.

External reference is the sum of the analogue references, pulses and bus references.

NOTE!

If *Sum* is selected, one of the preset references will always be active. If the preset references are to be without influence, they should be set to 0 % (as in the factory setting).

★ = General factory setting - also applying to spare part unit, **H** = HVAC setting, **I** = Industrial setting, () = parameter window text. [] = value for use in communication via serial communication port

FCM 300 Series

215 Preset reference 1 (PRESET REF. 1)

216 Preset reference 2 (PRESET REF. 2)

Settings:

-100.00 % - +100.00 % [-10000 - +10000]
 % of the reference range/external reference
 ★ 0.00% [0]

Function:

Two different preset references can be programmed in parameters 215-216.

The preset reference is stated as a percentage of the value Ref_{MAX} or as a percentage of the other external references, depending on the choice made in parameter 214. If a $Ref_{MIN} \neq 0$ has been programmed, the preset reference as a percentage will be calculated on the basis of the difference between Ref_{MAX} and Ref_{MIN} , following which the value is added to Ref_{MIN} .

Description of choice:

Set the fixed reference(s) that is/are to be the options.

To use the fixed references, it is necessary to have selected Preset ref. enable on terminal 2, 3, 4, or 5 (parameters 332 - 335).

Choices between fixed references can be made by activating terminal 2, 3, 4, or 5 - see the table below.

Terminals 2/3/4/5

Preset reference

Preset reference 1	0
Preset reference 2	1

219 Catch up/slow down value

(CATCH UP/SLW DWN)

Settings:

0.00 - 100.00 % [0 - 10000]
 ★ 0.00 % [0]

Function:

This parameter enables the entry of a percentage value (relative) which will either be added to or deducted from the actual reference.

Description of choice:

If *Catch up* has been selected via one of the terminals 2, 3, 4, or 5 (parameters 332 - 335), the percentage (relative) value selected in parameter 219 will be added to the total reference.

If *Slow down* has been selected via one of the terminals 2, 3, 4, or 5 (parameters 332 - 335), the percentage (relative) value selected in parameter 219 will be deducted from the total reference.

221 Current limit for motor mode

(CURRENT LIMIT)

Settings:

Min. limit (XX.X) - max. limit (XXX.X)
 in % of I_{RATED} [XXX - XXXX]
 ★ Max. limit (XXX.X) [XXXX]

I_{RATED} = rated motor current

Min. limit = magnetizing current in % of I_{RATED}

Max. limit = unit dependent limit in % of I_{RATED}

Function:

This function is relevant for all application configurations; speed and process regulation. This is where to set the current limit for motor operation.

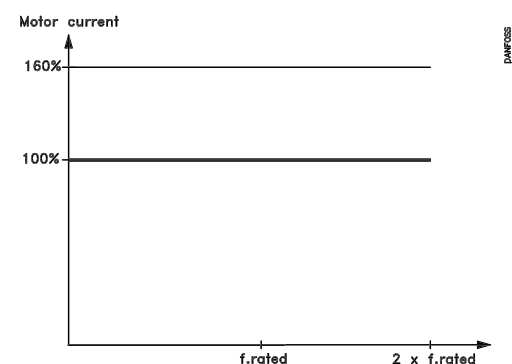
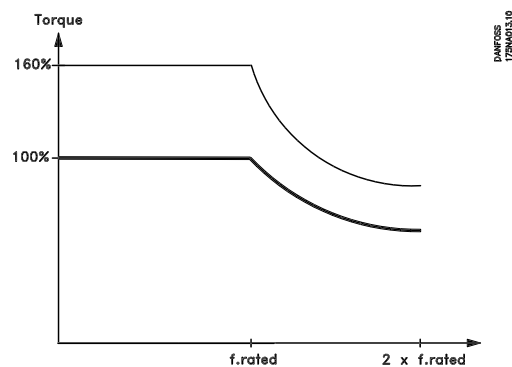

★ = General factory setting - also applying to spare part unit, **H** = HVAC setting, **I** = Industrial setting, () = parameter window text. [] = value for use in communication via serial communication port

Description of choice:

Set the desired % of current.

NOTE!

For motors with 2 poles (0.55 + 1.1 kW), the setting is limited to 120% which corresponds to 160% torque, setting 73% corresponds to 100% torque.

Description of choice:

Enter the frequencies to be avoided.

See also parameter 229.

229 Frequency bypass, bandwidth
(FREQ BYPASS B.W.)
Settings:

0 (OFF) - 100% [0-100]
 ★ 0 (OFF) % [0]

Function:

Some systems call for some output frequencies to be avoided because of resonance problems in the system.

In parameters 230-231 these output frequencies can be programmed for bypassing (Frequency bypass). In this parameter (229), a bandwidth can be defined on either side of these frequency bypasses.

Description of choice:

The bypass band is the bypass frequency +/- half the set bandwidth.

A percentage of the setting in parameters 230-231 is selected.

230 Frequency bypass 1 (FREQ. BYPASS 1)
231 Frequency bypass 2 (FREQ. BYPASS 2)
Settings:

0.0 - 132 Hz (parameter 200) [0 -]
 ★ 0.0 Hz [0]

Function:

Some systems call for some output frequencies to be avoided because of resonance problems in the system.

★ = General factory setting - also applying to spare part unit, **H** = HVAC setting, **I** = Industrial setting, () = parameter window text. [] = value for use in communication via serial communication port



FCM 300 Series

Chapter 11

- Parameters 317-340 page 11-2
Inputs and outputs

**317 Time out
(LIVE ZERO TIME O)**

Settings:
 1 - 99 sec. [1 - 99]
 ★ 10 sec. [10]

Function:

If the value of the reference signal connected to the input, terminal 1, falls below 50% of the setting in parameter 336 for a period longer than the time set in parameter 317, the function selected in parameter 318 will be activated.

Description of choice:

Set the desired time.

**318 Function after time out
(LIVE ZERO FUNCT.)**

Settings:
 ★ Off (OFF) [0]
 Stop and trip (STOP AND TRIP) [5]

Function:

This parameter allows a choice of the function to be activated if the value of the reference signal connected to the input, terminal 1, falls below 50% of the setting in parameter 336 for a period longer than the time set in parameter 317.

If a time-out function (parameter 318) occurs at the same time as a bus time-out function (parameter 514), the time-out function (parameter 318) will be activated.

**327 Pulse reference/feedback, max. frequency
(PULSE REF/FB MAX)**

Settings:
 100 - 70000 Hz [100 - 70000]
 ★ 5000 Hz [5000]

Function:

In this parameter, the signal value is set that corresponds to the maximum reference/feedback value set in parameter 205/415.

★ = General factory setting - also applying to spare part unit, **H** = HVAC setting, **I** = Industrial setting, () = parameter window text. [] = value for use in communication via serial communication port

Description of choice:

Set the desired pulse frequency.

NOTE!

Frequency limit:
 Open collector 24 V: 8 kHz
 Push pull 24 V: 70 kHz

**331 Terminal 1, analog input current
(AI [mA] 1 FUNCT)**
Settings:

H,I Reference (REFERENCE)	[1]
★ No operation (NO OPERATION)	[0]
Feedback (FEEDBACK)	[2]

Function:

This parameter allows a choice between the different functions available for the input, terminal 1.

Scaling of the input signal is effected in parameters 338 and 339.

Description of choice:

No operation. Is selected if the FCM 300 is not to react to signals connected to the terminal.

Reference. Is selected to enable change of reference by means of an analog reference signal.

If other inputs are connected, these are summed, taking account of their signs.

Feedback. Is selected if closed loop regulation with an analog signal is used.

NOTE!

If *Reference* or *Feedback* has been selected on more than one terminal, these signals will be summed.

332 Terminal 2, analog/digital input (DIGITAL INPUT 2)
333 Terminal 3, digital input (DIGITAL INPUT 3)
334 Terminal 4, digital input (DIGITAL INPUT 4)
335 Terminal 5, digital input (DIGITAL INPUT 5)

Function:

In parameters 332-335 it is possible to choose between the different possible functions related to the inputs on terminals 2-5. The function options are shown in the table below.

Parameter		332	333	334	335
Digital input on terminal no.		2	3	4	5
Settings:					
No function	(NO OPERATION)	[0]	[0]	[0]	[0]
Reset	(RESET)	[1]	★ [1]	[1]	[1]
Coasting stop, inverse	(MOTOR COAST INVERSE)	[2]	[2]	[2]	[2]
Reset and coasting stop, inverse	(RESET & COAST INV.)	[3]	[3]	[3]	[3]
Quick-stop, inverse	(QUICK STOP INVERSE)	[4]	[4]	[4]	[4]
DC-braking, inverse	(DC-BRAKE INVERSE)	[5]	[5]	[5]	[5]
Stop inverse	(STOP INVERSE)	[6]	[6]	[6]	[6]
Start	(START)	[7]	[7]	★ [7]	[7]
Latched start	(LATCHED START)	[8]	[8]	[8]	[8]
Reversing	(REVERSING)	[9]	[9]	[9]	[9]
Start reversing	(START REVERSING)	[10]	[10]	[10]	[10]
Start clockwise, on	(ENABLE FORWARD)	[11]	[11]	[11]	[11]
Start counter-clockwise, on	(ENABLE REVERSE)	[12]	[12]	[12]	[12]
Jog	(JOGGING)	[13]	[13]	[13]	★ [13]
Freeze reference	(FREEZE REFERENCE)	[14]	[14]	[14]	[14]
Freeze output	(FREEZE OUTPUT)	[15]	[15]	[15]	[15]
Speed up	(SPEED UP)	[16]	[16]	[16]	[16]
Speed down	(SPEED DOWN)	[17]	[17]	[17]	[17]
Selection of Setup	(SETUP SELECT)	[18]	[18]	[18]	[18]
Catch-up	(CATCH UP)	[19]	[19]	[19]	[19]
Slow-down	(SLOW DOWN)	[20]	[20]	[20]	[20]
Preset reference	(PRESET REF.)	[21]	[21]	[21]	[21]
Preset reference, on	(PRESET REF. ON)	[22]	[22]	[22]	[22]
Precise stop, inverse	(PRECISE STOP)			[23]	
Pulse reference	(PULSE REFERENCE)		[24]		
Pulse feedback	(PULSE FEEDBACK)		[25]		
Analog reference	(REFERENCE)	★ [30]			
Analog feedback	(FEEDBACK)	[31]			
Reset and start	(RESET AND START)	[32]	[32]	[32]	[32]

Description of choice:

No function is selected if the FCM 300 is not to react to signals transmitted to the terminal.

Reset resets the FCM 300 after an alarm; however, not all alarms can be reset without disconnecting from AC Line.

Coasting stop, inverse is used for making the FCM 300 run freely to stop. Logic '0' leads to coasting stop.

★ = General factory setting - also applying to spare part unit, **H** = HVAC setting, **I** = Industrial setting, () = parameter window text. [] = value for use in communication via serial communication port

Reset and coasting stop, inverse, is used for activating coasting stop at the same time as reset.

Logic '0' leads to coasting stop and reset.

Quick-stop, inverse is used for stopping the motor in accordance with the quick-stop ramp (set in parameter 212).

Logic '0' leads to a quick-stop.

DC braking, inverse is used for stopping the motor by energizing it with a DC voltage for a given time, see parameters 126-127.

Please note that this function is only active if the settings of parameters 126-127 is different from 0. Logic '0' leads to DC braking.

Stop inverse is activated by interrupting the voltage to the terminal. This means that if the terminal has no voltage, the motor cannot run. The stop will be effected in accordance with the selected ramp (parameters 207/208).



None of the above-mentioned stop commands are to be used as disconnection switch in connection with repairs. Disconnect AC Line.

Start, is selected if a start/stop command is desired. Logic '1' = start, logic '0' = stop (stand-by).

Latched start - if a pulse is applied for min. 20 ms, the motor will start, provided no stop command. The motor stops if Stop inverse is activated briefly.

Reversing is used for changing the direction of rotation of the motor shaft. Logic "0" will not lead to reversing. Logic "1" will lead to reversing. The reversing signal only changes the direction of rotation; it does not activate the start function.

Should not be used with *Process, closed loop mode*.

Start reversing, is used for start/stop and for reversing with the same signal. No start signal is allowed at the same time. Acts as latch start reversing, provided latch start has been chosen for another terminal.

Should not be used with *Process, closed loop mode*.

Start clockwise, on is used if the motor shaft is only to be able to rotate clockwise when starting.

Should not be used with *Process, closed loop mode*.

Start counter-clockwise, on is used if the motor shaft is to be able to rotate counter-clockwise when started.

Should not be used with *Process, closed loop mode*.

Jog is used for overriding the output frequency to the jog frequency set in parameter 213. The ramp time can be set in parameter 211. Jog is not active if a stop command has been given (start-disable).

Jog overrides stand-by.

Freeze reference - freezes the actual reference. The frozen reference is now the point of enable/condition for *Speed up* and *Speed down* to be used.

If speed up/down is used, the speed change always follows the normal ramp (parameters 207/208) in the range 0 - f_{MAX} .

Freeze output - freezes the actual motor frequency (Hz). The frozen motor frequency is now the point of enable/condition for *Speed up* and *Speed down* to be used.

Freeze output overrides start/stand-by, slip compensation and closed loop process control.

If speed up/down is used, the speed change always follows the normal ramp (parameters 207/208) in the range 0 - $f_{M,N}$.

Speed up and Speed down are selected if digital control of the up/down speed is desired (motor potentiometer). This function is only active if *Freeze reference* or *Freeze output* has been selected.

As long as there is a logic '1' on the terminal selected for speed up, the reference or the output frequency will increase.

As long as there is a logic '1' on the terminal selected for speed down, the reference or the output frequency will be reduced.

Pulses (logic '1' minimum high for 20 ms and a minimum pause of 20 ms) will lead to a change of speed of 0.1% (reference) or 0.1 Hz (output frequency).

★ = General factory setting - also applying to spare part unit, **H** = HVAC setting, **I** = Industrial setting, () = parameter window text. [] = value for use in communication via serial communication port

Example:

	Terminal		Freeze ref./ Freeze output
	2-5	2-5	
No speed change	0	0	1
Speed down	0	1	1
Speed up	1	0	1
Speed down	1	1	1

Selection of Setup, enables a choice of one of the two Setups; however, this presupposes that parameter 004 has been set to *Multi Setup*.

Catch-up/Slow-down is selected if the reference value is to be increased or reduced by a programmable percentage value set in parameter 219.

	Slow-down	Catch-up
Unchanged speed	0	0
Reduced by %-value	1	0
Increased by %-value	0	1
Reduced by %-value	1	1

Preset reference enables a choice of one of the two preset references, in accordance with the table in parameter 215 and 216. To be active, *Preset reference, on* has to be selected.

Preset reference, on is used for shifting between external reference and preset reference. It is assumed that *External/preset* [2] has been selected in parameter 214. Logic '0' = external references active; logic '1' = one of the two preset references is active.

Precise stop corrects the ramp-down time to obtain a high repetitive accuracy of the stopping point.

Pulse reference is selected if a pulse sequence (frequency) of 0 Hz is used, corresponding to Ref_{MIN}, parameter 204. The frequency is set in parameter 327, corresponding to Ref_{MAX}.

Pulse feedback is selected if a pulse sequence (frequency) is selected as a feedback signal.

Analog reference is selected to enable change of reference by means of an analog reference signal.

If other inputs are connected, these are summed, taking account of their signs.

Analog feedback is selected if closed loop regulation with an analog signal is used.

Reset and start is used for activating start at the same time as reset.

Scaling of the input signal is effected in parameters 338 and 339.

NOTE!

If *Reference* or *Feedback* has been selected on more than one terminal, these signals will be summed with signs.

336 Terminal 1, min. scaling (AI 1 SCALE LOW)

Settings:

0.0 - 20.0 mA	[0 - 200]
H,I 4.0 mA	[40]
★ 0.0 mA	[0]

Function:

This parameter determines the value of the reference signal that is to correspond to the minimum reference value set in parameter 204.

If the *Time-out* function of parameter 317 is to be used, the setting must be > 2 mA.

Description of choice:

Set the desired current value.

337 Terminal 1, max. scaling (AI 1 SCALE HIGH)

Setting:

0.0 - 20.0 mA	[0 - 200]
★ 20.0 mA	[200]

Function:

This parameter sets the value of the reference signal that is to correspond to the maximum reference value set in parameter 205.

Description of choice:

Set the desired current value.

★ = General factory setting - also applying to spare part unit, H = HVAC setting, I = Industrial setting, () = parameter window text. [] = value for use in communication via serial communication port

FCM 300 Series
**338 Terminal 2, min. scaling
(AI 2 SCALE LOW)**

Settings:
 0.0 - 10.0 V [0 - 100]
 ★ 0.0 V [0]

Function:
 This parameter is used for setting the signal value that corresponds to the minimum reference value set in parameter 204.

Description of choice:
 Set the desired voltage value.

**339 Terminal 2, max. scaling
(AI 2 SCALE HIGH)**

Settings:
 0.0 - 10.0 V [0 - 100]
 ★ 10.0 V [100]

Function:
 This parameter is used for setting the signal value that corresponds to the maximum reference value set in parameter 205.

Description of choice:
 Set the desired voltage value.

340 Terminal 9, output functions (OUTPUT FUNC.)

Settings:		
★ No function	(NO OPERATION)	[0]
Ready signal	(UNIT READY)	[1]
Enable, no warning	(ENABLE/NO WARNING)	[2]
H,I Running	(MOTOR RUNNING)	[3]
Running, no warning	(RUNNING NO WARNING)	[4]
Running on reference, no warning	(RUNNING ON REFERENCE)	[5]
Fault	(FAULT)	[6]
Fault or warning	(FAULT OR WARNING)	[7]
Current limit	(CURRENT LIMIT)	[8]
Thermal warning	(THERMAL WARNING)	[9]
Reversing	(REVERSE)	[10]
Off 123	(OFF 123 RELAY)	[11]
Actual frequency 0-20 mA	(0-FMAX = 0-20 mA)	[12]
Actual frequency 4-20 mA	(0-FMAX = 4-20 mA)	[13]
Reference _{MIN} - reference _{MAX} : 0-20 mA	(REF MIN-MAX =0-20 mA)	[14]
Reference _{MIN} - reference _{MAX} : 4-20 mA	(REF MIN-MAX =4-20 mA)	[15]
Feedback _{MIN} - feedback _{MAX} : 0-20 mA	(FB MIN-MAX =0-20 mA)	[16]
Feedback _{MIN} - feedback _{MAX} : 4-20 mA	(FB MIN-MAX =4-20 mA)	[17]
Actual current 0-20 mA	(0-IMAX = 0-20 mA)	[18]
Actual current 4-20 mA	(0-IMAX = 4-20 mA)	[19]
Mechanical brake	(MECHANICAL BRAKE)	[20]

Function:
 This output can act both as a digital and an analog output. If used as a digital output (data value [0]-[11]), a 24 V DC signal is transmitted; if used as an analog output (DATA VALUE [12]-[20]) either a 0-20 mA signal, or a 4-20 mA signal output.

Description of choice:
Unit Ready signal, the FCM 300 is ready for use.

Enable/no warning, the FCM 300 is ready for use; no start or stop command has been given (start/disable). No warning.

Motor Running, the output frequency is higher than 0.1 Hz. A start command has been given.

Running no warning, the output frequency is higher than 0.1 Hz. A start command has been given. No warning.

Running on reference, no warning, speed according to reference. No warning.

Fault, output is activated by alarm.

Fault or warning, the output is activated by alarm or warning.

★ = General factory setting - also applying to spare part unit, **H** = HVAC setting, **I** = Industrial setting, () = parameter window text. [] = value for use in communication via serial communication port

FCM 300 Series

Current limit, the current limit in parameter 221 has been exceeded.

$0-f_{MAX}$ (parameter 202) \Rightarrow 0-20 mA and
 $0-f_{MAX}$ (parameter 202) \Rightarrow 4-20 mA

Thermal warning, above the temperature limit in the frequency converter.

$Reference_{MIN}$ - $Reference_{MAX}$: 0-20 mA and
 $Reference_{MIN}$ - $Reference_{MAX}$: 4-20 mA

Reverse. Logic '1' = relay activated, 24 V DC on the output when the direction of rotation of the motor is clockwise. Logic '0' = relay not activated, no signal on the output, when the direction of rotation of the motor is counter-clockwise.

$Feedback_{LOW}$ - $Feedback_{HIGH}$: 0-20 mA and
 $Feedback_{LOW}$ - $Feedback_{HIGH}$: 4-20 mA

$0-I_{VLT, MAX}$ \Rightarrow 0-20 mA and
 $0-I_{VLT, MAX}$ \Rightarrow 4-20 mA

Off 123 relay, if Profidrive [0] has been selected in parameter 512, the output is activated. If either OFF1, OFF2 or OFF3 (bit in the control word) is logic '1'.

Mechanical brake, enables control of an optional external mechanical brake (see also parameter 138 and 139).

★ = General factory setting - also applying to spare part unit, **H** = HVAC setting, **I** = Industrial setting, () = parameter window text. [] = value for use in communication via serial communication port



FCM 300 Series

Chapter 12

- Parameters 400-446 page 12-2
Special functions

400 Brake functions (BRAKE FUNCTIONS)

Settings:

- ★ OFF (OFF) [0]
- AC brake (AC BRAKE) [4]

Function:

AC brake [4] can be selected to improve braking.

Description of choice:

Select AC brake [4] if short-term generated loads occur.

405 Reset function (RESET MODE)

Settings:

- H Automatic reset x 10 (AUTOMATIC X 10) [10]
- ★ Manual reset (MANUAL RESET) [0]
 - Automatic reset x 1 (AUTOMATIC X 1) [1]
 - Automatic reset x 2 (AUTOMATIC X 2) [2]
 - Automatic reset x 3 (AUTOMATIC X 3) [3]
 - Automatic reset x 4 (AUTOMATIC X 4) [4]
 - Automatic reset x 5 (AUTOMATIC X 5) [5]
 - Automatic reset x 6 (AUTOMATIC X 6) [6]
 - Automatic reset x 7 (AUTOMATIC X 7) [7]
 - Automatic reset x 8 (AUTOMATIC X 8) [8]
 - Automatic reset x 9 (AUTOMATIC X 9) [9]

Reset at power-up (RESET AT POWER UP) [11]

Function:

This parameter makes it possible to select the reset function desired after tripping.

After reset, the FCM 300 can be restarted after 1.5 sec.

Description of choice:

If *Manual reset* [0] is selected, reset must be effected via the digital inputs.

If the FCM 300 is to carry out an automatic reset (max. 1-10 times within 10 minutes) after tripping, select data value [1]-[10].



Warning:

The motor may start without warning up to 10 x 5 sec. after trip.

411 Switching frequency (SWITCH FREQ.)

Settings:

1.5 -14.0 kHz [1500 - 14000]

★ Unit dependent

Function:

The setting determines the switching frequency of the inverter. If the switching frequency is changed, this may help to minimize possible acoustic noise from the motor.

Description of choice:

When the motor is running, the switching frequency is adjusted in parameter 411 until the frequency has been obtained at which the motor is as low-noise as possible.

See also parameter 446 - switching pattern.

NOTE!

Switching frequencies higher than 4 kHz may cause thermal trip depending on ambient temperature.

412 Variable switching frequency (VAR CARRIER FREQ)

Settings:

Not possible (DISABLE) [0]

Variable switching freq. (VAR. CARRIER FREQ.) [1]

★ Temperature dep. sw. freq. (TEMP. DEP. FREQ.) [2]

Function:

This function makes it possible to change the switching frequency depending on the load. However, the maximum switching frequency is determined by the value set in parameter 411.

Description of choice:

Select *Not possible* [0] if a permanent switching frequency is desired. Set the switching frequency in parameter 411.

If *Variable switching frequency* [1] is selected the switching frequency will decline at an increasing output frequency. This is used in applications with square torque characteristics (centrifugal pumps and fans) in which the load declines depending on the output frequency.

★ = General factory setting - also applying to spare part unit, H = HVAC setting, I = Industrial setting, () = parameter window text. [] = value for use in communication via serial communication port

If *Temperature dependent switching frequency* [2] is selected, the switching frequency will decline at an increasing inverter temperature, see the drawing below.

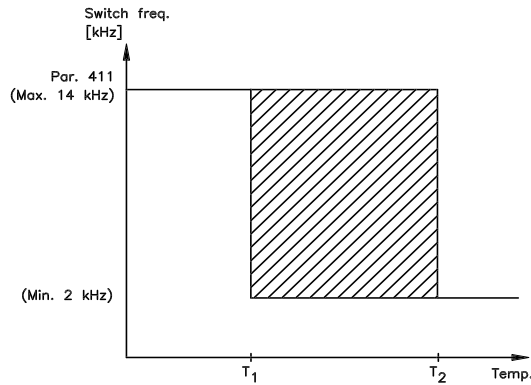

DANFOSS
175NA020.12

413 Overmodulation function (OVERMODULATION)

Settings:

- Off (OFF) [0]
- ★ On (ON) [1]

Function:

This parameter allows activation of the overmodulation function for the output voltage.

Description of choice:

Off means that there is no overmodulation of the output voltage, which means that torque ripple on the motor shaft is avoided. This can be a good feature, e.g. on grinding machines.

On means that an output voltage can be obtained which is greater than the mains voltage (up to 5%).

414 Minimum feedback (MIN. FEEDBACK)

Settings:

- 100,000,000 - FB_{HIGH} (par. 415) [-100000000 -]
- ★ 0.000 [0]

Function:

Parameters 414 and 415 are used to scale the feedback range to physical values used by the user. The setting will also be the bounds of the reference (parameters 204 and 205).

Used together with *Process, closed loop mode* (parameter 100).

Description of choice:

Is only active when parameter 203 has been set to *Min-Max* [0].

415 Maximum feedback (MAX. FEEDBACK)

Settings:

- (par. 414) FB_{LOW} - 100,000,000 [-100000000]
- H,I 100.000 [100000]
- ★ 1.500.000 [1500000]

Function:

See description of parameter 414.

416 Reference/feedback unit (REF/FEEDB. UNIT)

Settings:

- | | | | |
|---------------------|------|----------------------|------|
| NO UNIT | [0] | t/min | [21] |
| ★ % | [1] | t/h | [22] |
| PPM | [2] | m | [23] |
| RPM | [3] | Nm | [24] |
| bar | [4] | m/s | [25] |
| CYCLE/min | [5] | m/min | [26] |
| PULSE/s | [6] | °F | [27] |
| UNITS/s | [7] | in wg | [28] |
| UNITS/min | [8] | gal/s | [29] |
| UNITS/h | [9] | ft ³ /s | [30] |
| °C | [10] | gal/min | [31] |
| Pa | [11] | ft ³ /min | [32] |
| l/s | [12] | gal/h | [33] |
| m ³ /s | [13] | ft ³ /h | [34] |
| l/min | [14] | lb/s | [35] |
| m ³ /min | [15] | lb/min | [36] |
| l/h | [16] | lb/h | [37] |
| m ³ /h | [17] | lb ft | [38] |
| kg/s | [18] | ft/s | [39] |
| kg/min | [19] | ft/min | [40] |
| kg/h | [20] | Hz | [41] |

Function:

Choose among different units to be shown on the display.

This unit is also used directly in *Process regulation, closed loop* as a unit for *Minimum/Maximum reference* (parameters 204/205) and *Minimum/Maximum feedback* (parameters 414/415).

★ = General factory setting - also applying to spare part unit, H = HVAC setting, I = Industrial setting, () = parameter window text. [] = value for use in communication via serial communication port

The possibility of choosing a unit in parameter 416 will depend on the choices made in the following parameters:

- Par. 002 *Local/remote control.*
- Par. 013 *Local control/config. as par. 100.*
- Par. 100 *Configuration.*

Select parameter 002 as *Remote control*

If parameter 100 is selected as *Speed regulation, open loop*, the unit selected in parameter 416 can be used in displays (par. 009-12 *Feedback [unit]*) of process parameters.

Note: The reference can only be shown in Hz (*Speed regulation, open loop*).

If parameter 100 is selected as *Process regulation, closed loop*, the unit selected in parameter 416 will be used when displaying both reference (par. 009-12: *Reference [unit]*) and feedback (par. 009-12: *Feedback [unit]*).

Select parameter 002 as *Local control*

If parameter 013 is chosen as *LCP control and open loop* or *LCP digital control and open loop*, the reference will be given in Hz, regardless of the choice made in parameter 416. If parameter 013 is chosen as *LCP control/as par. 100* or *LCP digital control/as par. 100*, the unit will be as described above under parameter 002, Remote-control.

NOTE!

The above applies to display of *Reference [unit]* and *Feedback [unit]*. If *Reference [%]* or *Feedback [%]* is selected, the value displayed will be in the form of a percentage of the selected range.

Description of choice:

Select the desired unit for the reference/feedback signal.

**438 Process PID anti windup
(PROC ANTI WINDUP)**

Settings:

- Disable (DISABLE) [0]
- ★ Enable (ENABLE) [1]

Function:

It is possible to select whether the process regulator is to continue regulating on an error even if it is not possible to increase/reduce the output frequency. Used together with *Process, closed loop mode* (parameter 100).

Description of choice:

The factory setting is *Enable* [1], which means that the integration link is adjusted in relation to the actual output frequency if either the current limit or the max./min. frequency has been reached. The process regulator will not engage again until either the error is zero or its sign has changed.

Select *Disable* [0] if the integrator is to continue integrating on an error, even if it is not possible to remove the fault by such regulation.

NOTE!

If *Disable* [0] is selected, it will mean that when the error changes its sign, the integrator will first have to integrate down from the level obtained as a result of the former error, before any change to the output frequency occurs.

**439 Process PID start frequency
(PROC START VALUE)**

Settings:

- $f_{MIN}-f_{MAX}$ (parameter 201 and 202) X.X
- ★ parameter 201

Function:

When the start signal comes, the FCM 300 will react in the form of *Speed, open loop mode* following the ramp. Only when the programmed start frequency has been obtained, will it change over to *Process, closed loop mode*. In addition, it is possible to set a frequency that corresponds to the speed that the process normally rung which will enable the required process conditions to be reached sooner.

★ = General factory setting - also applying to spare part unit, **H** = HVAC setting, **I** = Industrial setting, () = parameter window text. [] = value for use in communication via serial communication port

Description of choice:

Set the required start frequency.

NOTE!

If the FCM 300 is running at the current limit before the desired start frequency is obtained, the process regulator will not be activated. For the regulator to be activated anyway, the start frequency must be lowered to the required output frequency. This can be done during operation.

**440 Process PID proportional gain
(PROC. PROP. GAIN)**

Settings:

0.00 (OFF) - 10.00 [0 - 1000]

H,I 0.3 [30]

★ 0.01 [1]

Function:

The proportional gain indicates the number of times the error between the set point and the feedback signal is to be applied.

Used together with *Process, closed loop mode* (parameter 100).

Description of choice:

Quick regulation is obtained by a high gain, but if the gain is too high, the process may become unstable.

**441 Process PID integral time
(PROC. INTEGR. T.)**

Settings:

0.01 - 9999 sec. (OFF) [1 - 999900]

H,I 20 sec. [2000]

★ 9999 sec. [999900]

Function:

The integrator provides an increasing gain at a constant error between the set point and the feedback signal. The greater the error, the quicker the gain will increase. The integral time is the time needed by the integrator to reach the same gain as the proportional gain.

Used together with *Process, closed loop mode* (parameter 100).

★ = General factory setting - also applying to spare part unit, **H** = HVAC setting, **I** = Industrial setting, () = parameter window text. [] = value for use in communication via serial communication port

Description of choice:

Quick regulation is obtained at a short integral time. However, if this time is set too short, the process can become unstable.

If the integral time is long, major deviations from the required set point may occur, since the process regulator will take a long time to regulate in relation to a given error.

**442 Process PID differentiation time
(PROC. DIFF. TIME)**

Settings:

0.00 (OFF) - 10.00 sec. [0 - 1000]

★ 0.00 sec. [0]

Function:

The differentiator does not react to a constant error. It only provides a gain when the error changes. The quicker the error changes, the stronger the gain from the differentiator.

The gain is proportional to the speed at which the error changes.

Used together with *Process, closed loop mode* (parameter 100).

Description of choice:

Fast regulation is obtained with a long differentiation time. However, if this time is set too long, the process can become unstable.

**443 Process PID diff. gain limit
(PROC. DIFF. GAIN)**

Settings:

5.0 - 50.0 [50 - 500]

★ 5.0 [50]

Function:

It is possible to set a limit for the differentiator gain.

The differentiator gain will increase if there are fast changes, which is why it can be beneficial to limit this gain, thereby obtaining a pure differentiator gain at slow changes and a constant differentiator gain where quick changes to the error occur.

Used together with *Process, closed loop mode* (parameter 100).

Description of choice:

Select a limit to differentiator gain as required.

**444 Process PID lowpass filter time
(PROC. FILTER TIME)**

Settings:

0.01 - 10.00 sec [1 - 1000]
 ★ 0.01 sec [1]

Function:

Oscillations on the feedback signal are dampened by the lowpass filter in order to reduce their impact on the process regulation. This can be an advantage e.g. if there is a lot of noise on the signal.

Used together with *Process, closed loop mode* (parameter 100).

Description of choice:

Select the desired time constant (τ). If a time constant (τ) of 100 ms is programmed, the break frequency for the lowpass filter will be $1/0.1 = 10$ RAD/sec., corresponding to $(10/2 \times \pi) = 1.6$ Hz.

The process regulator will thus only regulate a feedback signal that varies by a frequency lower than 1.6 Hz.

If the feedback signal varies by a higher frequency than 1.6 Hz, the Process regulator will not react.

FCM 300 Series

445 Flying start

(FLYING START)

Settings:

H OK - both directions (OK-BOTH DIRECTIONS) [2]
 ★ Disable (DISABLE) [0]
 OK - same direction (OK-SAME DIRECTION) [1]
 DC-brake before start
 (DC-BRAKE BEF. START) [3]

Function:

This function makes it possible to 'catch' a motor, which is spinning freely because of an AC Line drop-out.

Description of choice:

Select *Disable* if this function is not required.

OK - same direction: Chosen if the motor can only rotate in same direction on cut-in.

OK - both directions: Chosen if the motor can rotate in both directions on cut-in.

DC-brake - before start: Selected if the motor is to be stopped using DC brake before the motor is ramped up to the desired speed. The DC brake time must be set in parameter 126.

Limitations:

1. Too low inertia will cause acceleration of the load, which may be dangerous or prevent successful *Flying start*. Use DC brake instead.
2. If load is driven eg. by "windmilling", the unit might trip due to overvoltage.
3. Below 250 rpm the *Flying start* will not function.

446 Switching pattern

(SWITCH PATTERN)

Settings:

H 60° AVM (60° AVM) [0]
 ★ SFAVM (SFAVM) [1]

Description of choice:

Normally it is not necessary for the customer to set this parameter.

★ = General factory setting - also applying to spare part unit, H = HVAC setting, I = Industrial setting, () = parameter window text. [] = value for use in communication via serial communication port



FCM 300 Series

Chapter 13

- Parameters 500-543 page 13-2
Serial communication

FCM 300 Series
500 Address (BUS ADDRESS)

Settings:
 1 - 126 [1 -126]
 ★ 1 [1]

Function:
 This parameter allows specification of the address of each FCM 300. This feature is used in connection with PLC/PC connection.

Description of choice:
 The individual FCM 300 can be given an address between 1 and 126. The address 0 is used if a master (PLC or PC) wishes to send a telegram that is to be received by all FCM 300 connected to the serial communication port at the same time. In this case, the FCM 300 will not acknowledge receipt. If the number of units connected (FC M 300 + master) exceeds 31, a repeater is required.

501 Baudrate (BAUDRATE)

Settings:
 300 Baud (300 BAUD) [0]
 600 Baud (600 BAUD) [1]
 1200 Baud (1200 BAUD) [2]
 2400 Baud (2400 BAUD) [3]
 4800 Baud (4800 BAUD) [4]
 ★ 9600 Baud (9600 BAUD) [5]

Function:
 This parameter is for programming the speed at which data is to be transmitted via the serial connection. Baud rate is defined as the number of bits transferred per second.

Description of choice:
 The transmission speed of the FCM 300 is to be set at a value that corresponds to the transmission speed of the PLC/PC.

502 Coasting (COASTING SELECT)
503 Quick-stop (Q STOP SELECT)
504 DC-brake (DC BRAKE SELECT)
505 Start (START SELECT)
506 Reversing (REVERSING SELECT)
507 Selection of Setup (SETUP SELECT)
508 Selection of speed (PRES.REF. SELECT)

Settings:
 Digital input (DIGITAL INPUT) [0]
 Bus (SERIAL PORT) [1]
 Logic and (LOGIC AND) [2]
 ★ Logic or (LOGIC OR) [3]

Function:
 Parameters 502-508 allow a choice between controlling the FCM 300 via the terminals (digital input) and/or via the bus.

If (*Logic and*) or (*Bus*) is selected, the command in question can only be activated if transmitted via the serial communication port. In the case of *Logic and*, the command must additionally be activated via one of the digital inputs.

Description of choice:
Digital input [0] is selected if the control command in question is only to be activated via a digital input.

Bus [1] is selected if the control command in question is only to be activated via a bit in the control word (serial communication).

Logic and [2] is selected if the control command in question is only to be activated when a signal is transmitted (active signal = 1) via both a control word and a digital input.

Digital input	Bus	Control command
505-508		
0	0	0
0	1	0
1	0	0
1	1	1

Logic or [3] is selected if the control command in question is to be activated when a signal is given (active signal = 1) either via a control word or via a digital input.

★ = General factory setting - also applying to spare part unit, **H** = HVAC setting, **I** = Industrial setting, () = parameter window text. [] = value for use in communication via serial communication port

Digital input	Bus	Control command
505-508		
0	0	0
0	1	1
1	0	1
1	1	1

NOTE!

Parameters 502-504 deal with stop functions - see examples regarding 502 (coasting) below. Active stop command "0".

Parameter 502 = *Logic and*

Digital input	Bus	Control command
0	0	1 Coasting
0	1	0 Motor running
1	0	0 Motor running
1	1	0 Motor running

Parameter 502 = *Logic or*

Digital input	Bus	Control command
0	0	1 Coasting
0	1	1 Coasting
1	0	1 Coasting
1	1	0 Motor running

509 Bus jog 1 (BUS JOG 1 FREQ.)
Settings:

0.0 - parameter 202 [0 -]
 ★ 10.0 Hz [100]

Function:

This is where to set a fixed speed (jog) that is activated via the serial communication port.

This function is the same as in parameter 213.

Description of choice:

The jog frequency f_{JOG} can be selected in the range between f_{MIN} (parameter 201) and f_{MAX} (parameter 202).

FCM 300 Series
510 Bus jog 2 (BUS JOG 2 FREQ.)
Settings:

0.0 - parameter 202 [0 -]
 ★ 10.0 Hz [100]

Function:

This is where to set a fixed speed (jog) that is activated via the serial communication port.

This function is the same as in parameter 213.

Description of choice:

The jog frequency f_{JOG} can be selected in the range between f_{MIN} (parameter 201) and f_{MAX} (parameter 202).

512 Telegram profile (TELEGRAM PROFILE)
Settings:

Profidrive (PROFIDRIVE) [0]
 ★ FC Drive (FC DRIVE) [1]

Function:

There is a choice of two different control word profiles.

Description of choice:

Select the desired control word profile.

NOTE!

This is only possible in Stop Mode (motor stopped on a Stop command).

513 Bus time interval
(BUS TIMEOUT TIME)
Value:

1 - 99 sec. ★ 1 sec.

Function:

This parameter sets the maximum time expected to pass between the receipt of two consecutive telegrams. If this time is exceeded, the serial communication is assumed to have stopped and the desired reaction is set in parameter 514.

Description of choice:

Set the desired time.

★ = General factory setting - also applying to spare part unit, **H** = HVAC setting, **I** = Industrial setting, () = parameter window text. [] = value for use in communication via serial communication port

514 Bus time interval function	
(BUS TIMEOUT FUNC)	
Value:	
★ Off (OFF)	[0]
Freeze output (FREEZE OUTPUT)	[1]
Stop (STOP)	[2]
Jogging (JOGGING)	[3]
Max. speed (MAX SPEED)	[4]
Stop and trip (STOP AND TRIP)	[5]

Function:
 This parameter selects the desired reaction of the FCM 300 when the set time for bus timeout (parameter 513) has been exceeded. If choices [1] to [5] are activated, relay 01 and relay 04 will be deactivated.

Description of choice:
 The output frequency of the FCM 300 can: be frozen at the present value, be frozen at the reference, go to stop, go to jogging frequency (parameter 213), go to max. output frequency (parameter 202) or stop and activate a trip.

515 Data read-out: Reference %	
(REFERENCE)	
Value:	
XXX.X %	[XXXX]

Function:
 This parameter can be read out via the serial communication port.

Description of choice:
 The value shown corresponds to the total reference (sum of digital/analog/preset/bus/freeze ref./catch-up and slow-down).

 This value is updated every 320 ms.

516 Data read-out: Reference unit	
(REFERENCE [UNIT])	
Value:	
X.XXX Hz or rpm.	[XXXX]

Function:
 This parameter can be read out via the serial communication port.

Description of choice:
 Indicates the status value of the unit given on the basis of the choice of the reference sum.

 This value is updated every 320 ms.

517 Data read-out: Feedback	
(FEEDBACK [UNIT])	
Value:	
X.XXX	[XXXX]

Function:
 This parameter can be read out via the serial communication port.

Description of choice:
 Indicates the status value of terminals 1/2 at the unit/scale selected in parameters 414 and 415.

 This value is updated every 320 ms.

518 Data read-out: Frequency	
(FREQUENCY)	
Value:	
XXX.X Hz	[XXXX]

Function:
 This parameter can be read out via the serial communication port.

Description of choice:
 The value shown corresponds to the actual motor frequency.

 This value is updated every 320 ms.

519 Data read-out: Frequency x scale	
(FREQUENCY X SCALE)	
Value:	
XXX.X Hz	[XXXX]

Function:
 This parameter can be read out via the serial communication port.

★ = General factory setting - also applying to spare part unit, **H** = HVAC setting, **I** = Industrial setting, () = parameter window text. [] = value for use in communication via serial communication port

Description of choice:

The value corresponds to the present output frequency f_M multiplied by the factor preset in parameter 008 *Display scaling* of output frequency.

**520 Data read-out: Current
(MOTOR CURRENT)**

Value:

XXX.XX A [XXXXX]

Function:

This parameter can be read out via the serial communication port.

Description of choice:

The value shown is a calculated value of the given motor current.

This value is updated every 320 ms.

**521 Data read-out: Torque
(TORQUE)**

Value:

XXX.X % [XXXX]

Function:

This parameter can be read out via the serial communication port.

Description of choice:

The value shown is the torque, with sign, supplied by the motor shaft. The value is given as a percentage of the rated torque.

There is not exact linearity between 160% motor current and torque in relation to the rated torque. Some motors supply more torque than that. Consequently, the min. value and the max. value will depend on the max. motor current as well as the motor used.

This value is updated every 320 ms.

NOTE!

If the setting of the motor parameters does not match the motor applied, the read-out values will be inaccurate and may become negative, even if the motor is not running or is producing a positive torque.

**522 Data read-out: Power, kW
(POWER (kW))**

Value:

XX.XX kW [XXXX]

Function:

This parameter can be read out via the serial communication port.

Description of choice:

The value shown is calculated on the basis of the actual motor voltage and motor current.

This value is updated every 320 ms.

**523 Data read-out: Power, HP
(POWER (hp))**

Value:

XX.XX HP (US) [XXXX]

Function:

This parameter can be read out via the serial communication port.

Description of choice:

The value shown is calculated on the basis of the actual motor voltage and motor current. The value is indicated in the form of HP.

This value is updated every 320 ms.

★ = General factory setting - also applying to spare part unit, **H** = HVAC setting, **I** = Industrial setting, () = parameter window text. [] = value for use in communication via serial communication port

**524 Data read-out: Motor voltage
(MOTOR VOLTAGE)**

Value:
XXX.X V [XXXX]

Function:
This parameter can be read out via the serial communication port.

Description of choice:
The value shown is a calculated value used for controlling the motor.

This value is updated every 320 ms.

**525 Data read-out: DC link voltage
(DC LINK VOLTAGE)**

Value:
XXXX V [XXXX]

Function:
This parameter can be read out via the serial communication port.

Description of choice:
The value shown is a measured value.

The value is filtered, which means that approx. 1.3 seconds may pass from an input value changes until the data read-out changes values.

This value is updated every 320 ms.

**527 Data read-out: FC therm.
(FC THERMAL)**

Value:
0 - 100% [0 - 100]

Function:
This parameter can be read out via the serial communication port.

Description of choice:
Only whole numbers are displayed.

This value is updated every 160 ms.

**528 Data read-out: Digital input
(DIGITAL INPUT)**

Value:
Unit

Function:
This parameter can be read out via the serial communication port.

Description of choice:
The value shown indicates the signal status from the 4 digital terminals (2, 3, 4, and 5).

This value is updated every 20 ms.

**533 Data read-out: External reference %
(EXT. REFERENCE)**

Value:
-200.0 - +200.0 %

Function:
This parameter can be read out via the serial communication port.

Description of choice:
The value stated gives, as a percentage, the sum of external references (sum of analog/bus/pulse).

This value is updated every 80 ms.

**534 Data read-out: Status word, binary
(STATUS WORD [HEX])**

Value:
Unit

Function:
This parameter can be read out via the serial communication port.

★ = General factory setting - also applying to spare part unit, **H** = HVAC setting, **I** = Industrial setting, () = parameter window text. [] = value for use in communication via serial communication port



FCM 300 Series

Description of choice:

Indicates the status word transmitted via the serial communication port.

537 Data read-out: INV. temperature (INVERTER TEMP.)

Value:

Unit: °C

Function:

This parameter can be read out via the serial communication port.

Description of choice:

States the given temperature of the frequency converter. This value is updated every 10 sec.

538 Data read-out: Alarm word (ALARM WORD)

Value:

Unit

Function:

This parameter can be read out via the serial communication port. See chapter on "Warnings and alarms".

Description of choice:

States whether there is an alarm on the FCM 300.

Hex	Fault messages
00000002	Trip lock
00000040	HPFB timeout
00000080	Standard bus timeout
00000100	Short circuit
00000200	24 V supply fault
00000400	Earth fault
00000800	Overcurrent
00004000	Motor thermistor
00008000	Inverter overload
00010000	Undervoltage
00020000	Overvoltage
00040000	Phase loss
00080000	Live zero error
00100000	Overtemperature
02000000	HPFB error
08000000	Inrush fault
10000000	Internal error

NOTE!

This parameter is updated every 20 ms.

539 Data read-out: Control word (CONTROL WORD)

Value:

Unit

Function:

This parameter can be read out via the serial communication port.

Description of choice:

Indicates the control word sent via the serial communication port in Hex code from the FCM 300. This parameter is updated every 20 ms.

540 Data read-out: Warning word, 1 (WARN. WORD 1)

Value:

Unit

Function:

This parameter can be read out via the serial communication port. See chapter on "Warnings and alarms".

Description of choice:

States in Hex format whether there is a warning on the FCM 300.

Hex	Warning messages
00000008	HPFB timeout
00000010	Standard bus timeout
00000040	Current limit
00000200	Inverter overload
00001000	Voltage warning low
00002000	Voltage warning high
00004000	Phase loss
00010000	Live zero error warning
00400000	Output freq. limit warning
00800000	HPFB error
40000000	24 V supply warning
80000000	Inverter temp. high

★ = General factory setting - also applying to spare part unit, **H** = HVAC setting, **I** = Industrial setting, () = parameter window text. [] = value for use in communication via serial communication port

**541 Data read-out: Warning word, 2
(WARN. WORD 2)**

Value:
Unit

Function:

This parameter can be read out via the serial communication port.

Description of choice:

States in Hex format whether there is a warning on the FCM 300.

Hex	Status messages
01	Ramping
04	Start clockwise/ counterclockwise
08	Slow down
10	Catch-up
8000	Frequency limit

**542 Data read-out: Terminal 1, analog input
(ANALOG INPUT 1)**

Value:
Unit: mA

Function:

This parameter can be read out via the serial communication port.

Description of choice:

The value shown indicates the signal value on terminal 1.

The scaling (parameters 336 and 337) does not influence the read-out. Min. and max. are determined by the offset and gain adjustment of the AD-converter.

This value is updated every 20 ms.

**543 Data read-out: Terminal 2, analog input
(ANALOG INPUT 2)**

Value:
Unit: X.X V

Function:

This parameter can be read out via the serial communication port.

Description of choice:

The value shown indicates the signal value on terminal 2.

The scaling (parameters 338 and 339) does not influence the read-out. Min. and max. are determined by the offset and gain adjustment of the AD-converter.

This value is updated every 20 ms.

★ = General factory setting - also applying to spare part unit, **H** = HVAC setting, **I** = Industrial setting, () = parameter window text. [] = value for use in communication via serial communication port



FCM 300 Series

Chapter 14

- Parameters 600-635 page 14-2
Technical functions

FCM 300 Series

600 Operating data: Operating hours (OPERATING HOURS)

Value:

Unit: hours
0.0 - 130,000.0

Function:

This parameter can be read out via the display or the serial communication port. The value cannot be reset.

Description of choice:

Indicates the number of hours in which the FCM 300 has had AC Line voltage applied.

The value is updated in the FCM 300 every hour and saved when the unit is turned off.

601 Operating data: Hours run (RUNNING HOURS)

Value:

Unit: hours
0.0 - 130,000.0

Function:

This parameter can be read out via the display or the serial communication port. The value can be reset via parameter 619.

Description of choice:

Indicates the number of hours in which the FCM 300 has been in operation since reset in parameter 619.

The value is updated in the FCM 300 every hour and saved when the unit is turned off.

603 Operating data: Number of power-up's (POWER UP'S)

Value:

Unit: number
0 - 9999

Function:

This parameter can be read out via the display or the serial communication port.

Description of choice:

States the number of power-ups of the supply voltage to the FCM 300.

604 Operating data: Number of overtemperatures (OVER TEMP'S)

Value:

Unit: number
0 - 9999

Function:

This parameter can be read out via the display or the serial communication port.

Description of choice:

States the number of temperature faults there has been on the FCM 300.

605 Operating data: Number of overvoltages (OVER VOLT'S)

Value:

Unit: number
0 - 9999

Function:

This parameter can be read out via the display or the serial communication port.

Description of choice:

States the number of overvoltages there has been on the FCM 300.

★ = General factory setting - also applying to spare part unit, **H** = HVAC setting, **I** = Industrial setting, () = parameter window text. [] = value for use in communication via serial communication port

FCM 300 Series
**615 Fault log: Error code
(F.LOG: ERROR COD)**

Value:
[Index XX - XXX]

Function:

Array type parameter. This parameter makes it possible to see the reason why a trip occurs.

10 log values are stored.

The lowest log number (1) contains the latest/most recently saved data value; the highest log number (10) contains the oldest data value.

For additional information, see chapter on "Warnings and alarms".

Description of choice:

Read out as a figure code between 1 and 37.

Fault code	Alarm
0	No fault
1	
2	Live zero error
3	
4	Phase loss
7	Overvoltage
8	Undervoltage
9	Inverter overload
11	Motor thermistor
13	Overcurrent
14	Earth fault
15	Supply fault
16	Short circuit
17	Standard BUS time out
18	HPFB time out
34	HPFB error
35	Inrush fault
36	Overtemperature
37	Internal error

The fault log is reset after initialisation in parameter 620.

**616 Fault log: Time
(F.LOG: TIME)**

Value:
Unit: Hours
[Indication range XX - XXX]

Function:

Array type parameter. This parameter makes it possible to see the total number of operating hours before the trip occurred.

10 (1-10) log values are stored.

The lowest log number (1) contains the latest/most recently saved data value, while the highest log number (10) contains the oldest data value.

Description of choice:

Read out as an option.

Indication range: XX - XXX.

The fault log is reset after initialization (para. 620).

★ = General factory setting - also applying to spare part unit, **H** = HVAC setting, **I** = Industrial setting, () = parameter window text. [] = value for use in communication via serial communication port

FCM 300 Series

**617 Fault log: Value
(F.LOG: VALUE)**

Value:

[Index XX - XXX]

Function:

Array type parameter. This parameter makes it possible to see at what current or voltage a given trip occurred.

Description of choice:

Read out as one value.

Indication range: 0.0 - 999.9.

The fault log is reset after initialization (para. 620).

**619 Reset of hours-run counter
(RESET RUN. HOUR)**

Settings:

- ★ No reset (DO NOT RESET) [0]
- Reset (RESET COUNTER) [1]

Function:

Reset to zero the hours-run counter (parameter 601).

Description of choice:

If *Reset* [1] has been selected the hours-run counter of the FCM 300 is reset.

620 Operating mode (OPERATION MODE)

Settings:

- ★ Normal function (NORMAL OPERATION) [0]
- Control card test (CONTROL CARD TEST) [2]
- Initialization (INITIALIZE) [3]

Function:

In addition to its normal function, this parameter can be used for two different tests.

Also, all parameters (except parameters 603-605) can be initialized.

Description of choice:

Normal function [0] is selected for normal operation with the motor in the selected application.

Control card test [2] is selected if control of the analog and digital inputs, as well as the analog, digital outputs and the +10 V control voltage is desired.

A test connector with internal connections is required for this test. Setup: Analog/digital output to digital inputs 3, 4 and 5 and 10 V supply to analog/digital input 2.

Initialization [3] is selected if the factory setting of the unit is desired without resetting parameters 500, 501 + 600 - 605. Initialization is active after power up.

621 Nameplate: FC type (FC TYPE)

Value:

Depends on unit

Function:

The key data of the unit can be read out via the serial communication port.

Description of choice:

Type indicates the unit size and basic function concerned.

**624 Nameplate: Software version no.
(SOFTWARE VERSION)**

Value:

Depends on unit

Function:

The key data of the unit can be read out the serial communication port.

Description of choice:

Software version gives the version number.

★ = General factory setting - also applying to spare part unit, **H** = HVAC setting, **I** = Industrial setting, () = parameter window text. [] = value for use in communication via serial communication port

FCM 300 Series

**625 Nameplate: LCP identification no.
(LCP VERSION)**

Value:
Depends on unit

Function:
The key data of the unit can be read out via the display or the serial communication port.
For example: ID 1,42 2 kB.

**626 Nameplate: Database identification no.
(DATABASE VER.)**

Value:
Depends on unit

Function:
The key data of the unit can be read out via the display or the serial communication port.

**628 Nameplate: Application option type
(APP. OPTION)**

Value:

Function:
The key data of the unit can be read out via the display or the serial communication port.

**630 Nameplate: Communication option type
ordering no. (COM. ORDER NO)**

Value:

Function:
The key data of the unit can be read out via the display or the serial communication port.

**632 BMC software identification
(BMC SW VERSION)**

Value:

Function:
The key data of the unit can be read out via the display or the serial communication port.

**633 Motor database identification
(MOTOR DATA VERS.)**

Value:

Function:
The key data of the unit can be read out via the display or the serial communication port.

**634 Unit identification for communication
(UNIT ID)**

Value:

Function:
The key data of the unit can be read out via the display or the serial communication port.

**635 Software part No
(SW. PART NO.)**

Value:

Function:
Indicates the software part No.

For information on the Profibus parameter group 800 - 900, see the FCM Profibus manual MG.03.EX.YY.

★ = General factory setting - also applying to spare part unit, **H** = HVAC setting, **I** = Industrial setting, () = parameter window text. [] = value for use in communication via serial communication port

Chapter 15

- Danfoss PC Software page 15-2
- Serial bus page 15-3
- Telegram Communication page 15-3
- Telegram Build-up page 15-3
- Data Bytes page 15-4

■ Danfoss PC software for serial communication

Using serial communication makes it possible to monitor, program and control one or several units from a centrally placed computer. All FCM 300 Series have an RS 485 port as standard, which enables them to communicate e.g. with a PC. A program entitled VLT® Software Dialog is available for this purpose.

VLT® Dialog operates in the familiar Windows® format.

VLT® Dialog incorporates three modules on one disk. The CD includes the Basic, Logging and Template Modules, as well as operating instructions - all in six different languages.

Basic Module

**TEST RUN**

is used for controlling and commissioning of a FCM 300, including:

- setting of reference value,
- simultaneous display of selected parameters in graphs,
- option of DDE link, e.g. to a spreadsheet.

**PARAMETER SETUP**

is used for setting up and transferring parameter sets, including:

- setting of FCM 300 parameters,
- parameter sets can be obtained from and copied to a FCM 300,
- documentation/print-out of the Setup including diagrams.

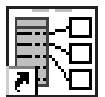
**BUS ADDRESS SETUP**

is used for setting the bus addresses on individual FCM 300 nocaps. "units" which are connected to the same bus.

- setting bus addresses
- storing list of units
- reporting list of units

Logging Module:

**LOGGING**

is used for collecting and displaying historical or real-time operating data:

- graphical representation of selected parameters from several FCM 300 units
- collection of log data to file,
- option of DDE link e.g. to a spreadsheet.

**MODEM SETUP**

is used for setting up the modem.

- sets the FCM 300 modem via the communication port of the PC.

Template Module:

**TEMPLATE SETUP**

is used for setting up template files for PARAMETER SETUP:

- the template file functions as a mask that limits the number of accessible parameters when a parameter file is to be made or edited in PARAMETER SETUP,
- the template file may contain preset values for the parameters of the FCM 300.

NOTE!

The logging and template module calls for a Basic module to be installed on the same PC.

Guided Tour:

The Guided Tour offers a demonstration of the VLT Software Dialog program.

■ **Serial bus**

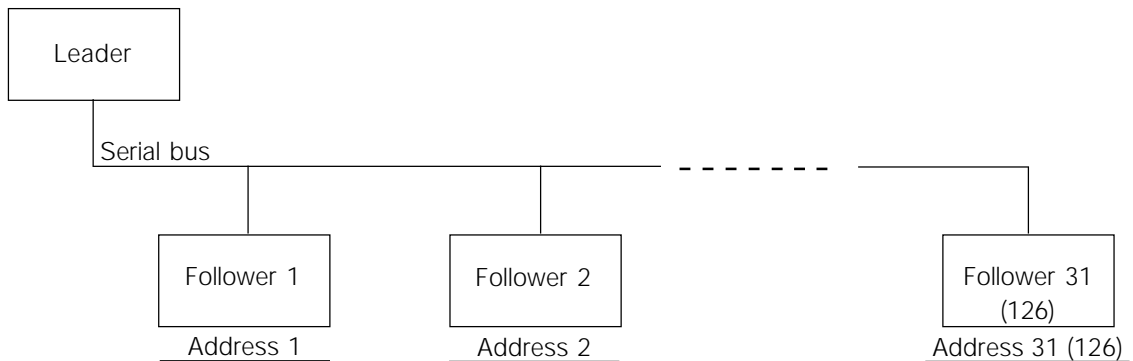

■ **Telegram communication**

Control and reply telegrams

The telegram communication in a leader/follower system is controlled by the leader. A maximum of 31 followers (FCM 300 units) can be connected to one leader, unless a repeater is used - see also the description of the address format.

The leader continuously sends control telegrams addressed to the followers and awaits reply telegrams from these. The response time of the followers is maximum 50 ms.

Only a follower that has received a faultless telegram addressed to that follower will respond by sending back the telegram unchanged.

Broadcast

A leader can send the same telegram at the same time to all followers connected to the bus. In such *broadcast* communication, the control telegram *broadcast* bit of the address bit has a value of 1 (see *VLT address*). Address bits 0-4 are not used.

Contents of a byte

Each transmitted sign begins with a start bit. Subsequently, 8 databits are transmitted. Each sign is given via a parity bit set at "1" when there is an even parity (i.e. an even number of binary 1's in the 8 databits and parity bits together). The sign ends with a stop bit and thus consists of a total of 11 bits.

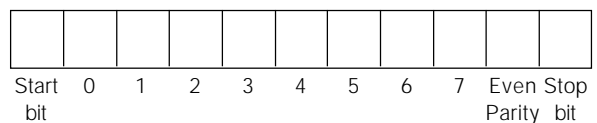

■ **Telegram build-up**

Each telegram begins with a startbyte (STX) = 02 Hex, followed by a byte that gives the telegram length (LGE) and a byte that gives the address (ADR).

Then follows a number of databytes (variable, depending on telegram type). The telegram ends with a data control byte (BCC).

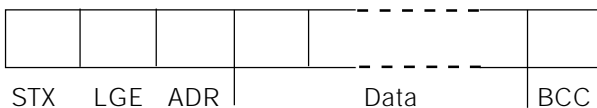

Telegram length (LGE)

The telegram length is the number of databytes plus address byte ADR plus data control byte BCC.

Telegrams with 4 databytes have a length of:

$$LGE = 4 + 1 + 1 = 6 \text{ bytes}$$

Telegrams with 12 databytes have a length of:

$$LGE = 12 + 1 + 1 = 14 \text{ bytes}$$

VLT address (ADR)

Two different address formats are used:

1. Siemens USS protocol address format:

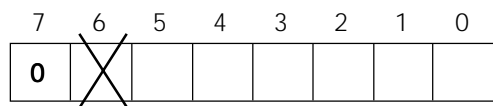

Bit 7 = 0

Bit 6 is not used

Bit 5 = 1: Broadcast, address bits (0-4) are not used

Bit 5 = 0: No Broadcast

Bits 0-4 = VLT address 1-31

2. Danfoss format:

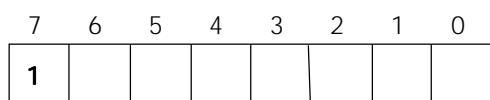

Bit 7 = 1

Bits 0-6 = VLT address 1-127 (0 = Broadcast)

Data control byte (BCC)

The data control byte can best be explained by means of an example: Before the first sign of the telegram is received, BCC = 0.

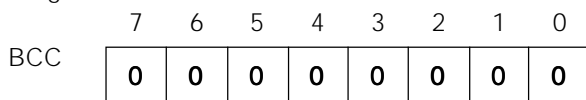

After the first sign has been received:

$$BCC_{NEW} = BCC_{OLD} \text{ EXOR "first byte"}$$

(EXOR = exclusive-or gate)

$$BCC_{OLD} = 00000000$$

$$\text{"first byte"} = 00000100 \text{ (02H)}$$

$$BCC_{NEW} = 00000100$$

Each additional, subsequent byte is gated by BCC_{OLD} EXOR and gives a new BCC_{NEW} , e.g.:

$$BCC_{OLD} = 00000100$$

$$\text{"second byte"} = 11010110 \text{ (D6H)}$$

$$BCC_{NEW} = 11010100$$

The result after the last received sign is BCC.

■ Databytes

The block of databytes is divided into two smaller blocks:

1. Parameter bytes used for transferred parameters between leader and follower
2. Process bytes, covering
 - Control word and reference value (from leader to follower)
 - Status word and present output frequency (from follower to leader)

This structure applies to both the control telegram (leader→follower) and the reply telegram (follower→leader).

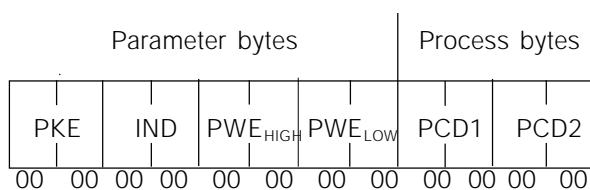

There are two types of telegrams:

- with 12 bytes built up as shown above, with parameter and process block
- with four bytes, which is the process block from the 12 byte telegram

1. Parameter bytes

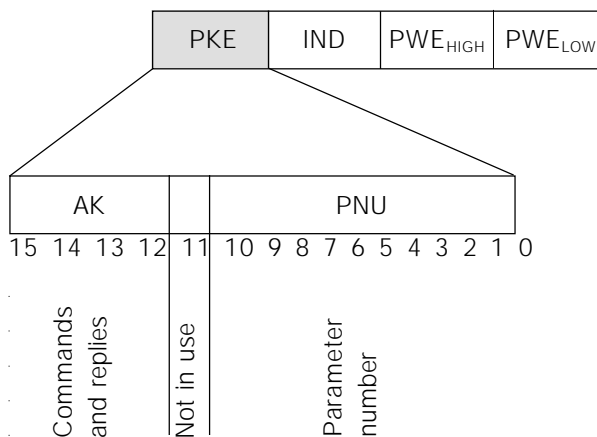

Commands and replies (AK)

Bits no. 12-15 are used for transmitting commands from leader to follower and the follower's processed reply back to the leader.

FCM 300 Series

Commands leader→follower:

Bit no.

15	14	13	12	Command
0	0	0	0	No command
0	0	0	1	Read parameter value
0	0	1	0	Write parameter value in RAM (word)
0	0	1	1	Write parameter value in RAM (double word)
1	1	0	1	Write parameter value in RAM and EEPROM (double word)
1	1	1	0	Write parameter value in RAM and EEPROM (word)
1	1	1	1	Read text

Reply follower→leader:

Bit no.

15	14	13	12	Reply
0	0	0	0	No reply
0	0	0	1	Parameter value transferred (word)
0	0	1	0	Parameter value transferred (double word)
0	1	1	1	Command cannot be executed
1	1	1	1	Text transferred

If the command cannot be executed, the follower will send this reply (0111) and give the following error message in the parameter value:

Error code

(reply 0111)	Error message
0	The parameter number used does not exist
1	There is no write access to the parameter called
2	The data value exceeds the parameter limits
3	The used sub-index does not exist
4	The parameter is not of the array type
5	The data type does not match the parameter called
17	Data change in the parameter called is not possible in the present mode of the FCM 300. E.g. some parameters can only be changed when the motor has stopped
130	There is no bus access to the parameter called
131	Data change is not possible because factory Setup has been selected

Parameter number (PNU)

Bits no. 0-10 are used for transmitting parameter numbers. The function of a given parameter can be seen from the parameter description in chapter 8.

PKE	IND	PWE
-----	-----	-----

Index

Index is used together with the parameter number for read/write access to parameters of the *array* type (par. 615, 616 and 617).

Parameter value (PWE)

PKE	IND	PWE
-----	-----	-----

The parameter value depends on the command given. If the leader wants a parameter (read), it does not care about the PWE block value. If a parameter is changed by the leader (write), the new value is transferred in the PWE block. If the follower replies to a parameter request (read command), the present parameter value is transferred to the PWE block.

The transferred value corresponds to the figures given in the parameter descriptions. E.g. parameter 101, where [1] corresponds to *Constant torque*, [2] corresponds to *Variable torque: low*, etc. However, parameters with data type 9 (text string) are excepted, as this text is transferred as an ASCII text string. When a text string is transferred (read), the telegram length is variable, since the texts have different lengths. The telegram length is stated in the 2nd byte of the telegram, called LGE.

Parameters 621-634 (nameplate data) have data type 9 (text string).

Data types supported by the FCM 300 unit

Data type	Description
3	Integer 16
4	Integer 32
5	Unsigned 8
6	Unsigned 16
7	Unsigned 32
9	Text string

Unsigned means there is no sign included in the telegram.

FCM 300 Series

The different attributes for each parameter can be seen in the section on factory settings.

Since a parameter value can only be transferred as an integer, a conversion factor must be used to transfer decimals.

Example:

Parameter 201: minimum frequency, conversion factor 0,1. If parameter 201 is to be set to 10 Hz, a value of 100 must be transferred, since a conversion factor of 0,1 means that the transferred value will be multiplied by 0.1. A value of 100 will thus be understood as 10.

Addressing by unit ID

The unit ID is printed on the label on the plastic cover under the lid of the electronics box. The three groups of unit ID each with three digits must be converted to Hex. The desired address is added as the last byte. The frame is sent to the bus address parameter(s) 500 (and 918) via a broadcast.

Unit ID:	0-255	0-255	1-255		
	↓	↓	↓		
PKE	IND	00-FF	00-FF	01-FF	Address

PKE: Write to parameter No. 500 or 918

IND: Not Used

2. Process-bytes

The process byte block is divided into two blocks each of 16 bits, which always come in the sequence stated.

PCD1	PCD2
------	------

(parameter 512 = Profdrive)

The control word is used for transmitting commands from a leader (e.g. a PC) to a follower (FCM 300).

Leader→Follower

		Control word	Bus reference													
15	14	13	12	11	10	9	8	7	6	5	4	3	2	1	0	Bit no.
Bit	Bit = 0															Bit = 1
00	OFF 1															ON 1
01	OFF 2															ON 2
02	OFF 3															ON 3
03	Motor coasting															Enable
04	Quick-stop															Ramp
05	Freeze output frequency															Ramp enable
06	Ramp stop															Start
07	No function															Reset
08	Jog 1 OFF															ON
09	Jog 2 OFF															ON
10	Data not valid															Valid
11	No function															Slow down
12	No function															Catch-up
13	Choice of Setup															
14																
15	No function															Reversing

PCD1 PCD2

Control telegram Control word Reference value
(leader→follower)

Reply telegram Status word Given output
(follower→leader) frequency

Bit 00, OFF1/ON1:

An ordinary ramp stop which uses the ramp time in parameters 207/208. Bit 00 = "0" leads to a stop and to output being activated, the output frequency is 0 Hz, provided *OFF 123* has been selected in parameter 340. Bit 00 = "1" means that the adjustable frequency drive will be able to start if the other conditions for starting have been fulfilled.

Bit 01, OFF2/ON2:

Coasting stop. Bit 01 = "0" leads to a coasting stop and leads to output being activated, when the output frequency is 0 Hz, provided *OFF 123* has been selected in parameter 340. Bit 01 = "1" means that the adjustable frequency drive is able to start, provided the other conditions for starting are fulfilled.

Bit 02, OFF3/ON3:

Quick-stop, which uses the ramp time in parameter 212. Bit 02 = "0" leads to a quick-stop and leads to output being activated, when the output frequency is 0 Hz, provided *OFF 123* has been selected in parameter 340. Bit 02 = "1" means that the adjustable frequency drive is able to start, provided the other conditions for starting are fulfilled.

Bit 03, Coasting/enable:

Coasting. Bit 03 = "0" leads to a stop. Bit 03 = "1" means that the adjustable frequency drive is able to start, provided the other conditions for starting are fulfilled. Note: In parameter 502 the choice is made as to how bit 03 is to be combined (gated) with the corresponding function in the digital inputs.

Bit 04, Quick-stop/ramp:

Quick-stop which uses the ramp time in parameter 212. Bit 04 = "0" leads to a quick-stop. Bit 04 = "1" means that the adjustable frequency drive is able to start, provided the other conditions for starting are fulfilled.

Note: In parameter 503 the choice is made as to how bit 04 is to be combined (gated) with the corresponding function on the digital inputs.

Bit 05, Freeze output frequency/ramp enable:

Bit 05 = "0" means that the given output frequency is maintained even if the reference is changed. Bit 05 = "1" means that the adjustable frequency drive is again able to regulate, and the given reference is followed.

Bit 06, Ramp stop/start:

An ordinary ramp stop that uses the ramp time in parameters 207/208; in addition, output will be activated when the output frequency is 0 Hz, provided *OFF 123* has been selected in parameter 340. Bit 06 = "0" leads to a stop. Bit 06 = "1" means that the adjustable frequency drive is able to start, provided the other conditions for starting are fulfilled. Note: In parameter 505 the choice is made as to how bit 06 is to be combined (gated) with the corresponding function on the digital inputs.

Bit 07, No function/reset

Reset of trip. Bit 07 = "0" means that there is no reset. Bit 07 = "1" means that a trip is reset. After reset it will take approx. 1.5 second until the unit is ready. The status word will indicate the ready state.

Bit 08, Jog 1 OFF/ON:

Activation of pre-programmed speed in parameter 509 (Bus JOG 1). JOG 1 is only possible when Bit 04 = "0" and bit 00-03 = "1".

Bit 09, Jog 2 OFF/ON:

Activation of pre-programmed speed in parameter 510 (Bus JOG 2). JOG 2 is only possible when Bit 04 = "0" and Bits 00-03 = "1". If both JOG 1 and JOG 2 are activated (Bits 08 and 09 = "1"), JOG 1 has the higher priority, which means that the speed programmed in parameter 509 will be used.

Bit 10, Data not valid/valid:

Used for telling the FCM 300 whether the control word is to be used or ignored. Bit 10 = "0" means that the control word is ignored. Bit 10 = "1" means that the control word is used. This function is relevant

because the control word is always contained in the telegram, regardless of the type of telegram used, i.e. it is possible to disconnect the control word if it is not to be used in connection with updating or reading of parameters.

Bit 11, No function/slow down:

Used for reducing the speed reference by the value in parameter 219. Bit 11 = "0" means that there is no change of the reference. Bit 11 = "1" means that the reference is reduced.

Bit 12, No function/catch-up:

Used for increasing the speed reference by the value of parameter 219. Bit 12 = "0" means that there is no change of the reference; Bit 12 = "1" means that the reference is increased. If both slow down and catch-up are activated (Bits 11 and 12 = "1"), slow down has the higher priority, i.e. the speed reference is reduced.

Bits 13, Choice of Setup:

Bit 13 is used for choosing between the two menu Setups in accordance with the following table:

Setup	Bit 13
1	0
2	1

This function is only possible if *Multi-Setups* have been selected in parameter 004.

NOTE!

Parameter 507 is used for choosing how Bit 13 is to be combined (gated) with the corresponding function on the digital inputs.

Bit 15, No function/reversing:

Reversing of the direction of rotation of the motor. Bit 15 = "0" leads to no reversing, Bit 15 = "1" leads to reversing.

NOTE!

Unless otherwise mentioned, the control word bit is combined (gated) with the corresponding function on the digital inputs as a logic "or" function.

Status word (according to profidrive standard)
The status word is used for informing the leader (e.g. a PC) of the condition of a follower (FCM 300).

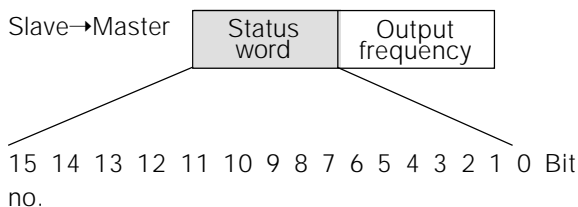

Bit	Bit = 0	Bit = 1
00	Control not ready	Ready
01	FC not ready	Ready
02	Motor coasting	Enable
03	No fault	Trip
04	ON 2	OFF 2
05	ON 3	OFF 3
06	Start enable	Start disable
07	No warning	Warning
08	Speed ≠ ref.	Speed = ref.
09	Reserved	
10	Reserved	
11	Not running	Running
12		
13	Voltage OK	Above limit
14	Torque OK	Above limit
15	Timer OK	Above limit

Bit 00, Control not ready/ready:

Bit 00 = "0" means that bit 00, 01 or 02 of the control word is "0" (OFF1, OFF2 or OFF3), or that the adjustable frequency drive has tripped. Bit 00 = "1" means that the adjustable frequency drive control is ready.

Bit 01, FC not ready/ready:

Same meaning as bit 00; however, there is also a supply to the power section, and the adjustable frequency drive is ready to run when it receives the necessary start signals.

Bit 02, Coasting/enable:

Bit 02 = "0" means that the control word bit 00, 01, 02 or 03 is "0" (OFF1, OFF2, OFF3 or Coasting), or the FCM 300 Series unit has tripped. Bit 02 = "1" means that the control word bits 00, 01, 02 or 03 are "1" and that the FCM 300 has not tripped.

Bit 03, No fault/trip:

Bit 03 = "0" means that FCM 300 Series is not in a fault condition. Bit 03 = "1" means that FCM 300 Series has tripped and needs a reset signal in order to run.

Bit 04, ON2/OFF2:

Bit 04 = "0" means that control word bit 01 = "1".
Bit 04 = "1" means that control word bit 01 = "0".

Bit 05, ON3/OFF3:

Bit 05 = "0" means that control word bit 02 = "1".
Bit 05 = "1" means that control word bit 02 = "0".

Bit 06, Start enable/start disable:

Bit 06 is always "0" if *FC Drive* has been selected in parameter 512. If *Profidrive* has been selected in parameter 512, bit 06 will be "1" after reset of a trip, after activation of OFF2 or OFF3 and after connection of mains voltage. *Start disable* is reset, setting control word bit 00 to "0" and bits 01, 02 and 10 to "1".

Bit 07, No warning/warning:

Bit 07 = "0" means that there is no unusual situation. Bit 07 = "1" means that an abnormal condition has arisen for the FCM 300.

Bit 08, Speed ≠ ref/speed. = ref.:

Bit 08 = "0" means that the actual motor speed is different from the speed reference set. This can be the case i.a. while the speed is ramped up/down during start/stop. Bit 08 = "1" means that the present motor speed equals the speed reference set.

Bit 11, Does not run/runs:

Bit 11 = "0" means that the motor is not running.
Bit 11 = "1" means that the FCM 300 has a start signal or that the output frequency is greater than 0 Hz.

Bit 13, Voltage OK/above limit:

Bit 13 = "0" means that the voltage limits of the FC motor have not been exceeded. Bit 13 = "1" means that the DC voltage of the FCM 300 intermediate circuit is too low or too high.

Bit 14, Torque OK/above limit:

Bit 14 = "0" means that the motor current is lower than the torque limit selected in parameter 221. Bit 14 = "1" means that the torque limit in parameter 221 has been exceeded.

Bit 15, Timers OK/above limit:

Bit 15 = "0" means that the timers for motor thermal protection and VLT thermal protection, respectively, have not exceeded 100%. Bit 15 = "1" means that one of the timers has exceeded 100%.

Control word under VLT standard (parameter 512 = FC Drive)

The control word is used for sending commands from a leader (e.g. a PC) to a follower (FCM 300).

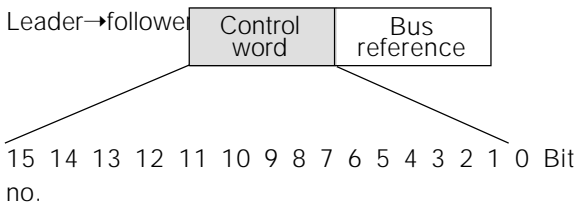

Bit	Bit = 0	Bit = 1
00	Preset reference choice	
01	No function	
02	DC brake	Ramp
03	Coasting	Enable
04	Quick-stop	Ramp
05	Hold	Ramp enable
06	Ramp stop	Start
07	No function	Reset
08	No function	Jog
09	No function	
10	Data not valid	Valid
11	No function	Output activates
12	No function	
13	Choice of Setup	
15	No function	Reversing

Bit 00:

Bit 00 is used for choosing between the two pre-programmed references (parameters 215-216) in accordance with the following table:

Preset ref.	Parameter	Bit 00
1	215	0
2	216	1

NOTE!

Parameter 508 is where to choose the way bits 1/12 are to be combined (gated) with the corresponding function on the digital inputs.

Bit 02, DC brake:

Bit 02 = "0" leads to DC braking and stop. Braking current and duration are set in parameters 132 and 133. Bit 02 = "1" leads to *ramp*.

Bit 08, Activation of Jog speed in parameter 213:

Bit 08 = "0": Jog speed not activated. Bit 08 = "1" means that the motor is running at Jog speed.

Bit 11, Output

Bit 11 = "0": Output not activated. Bit 11 = 1: Output activated, provided *Off 123* has been chosen in parameter 340.

See the description of other bits under control word for Profidrive standard.

NOTE!

Unless otherwise mentioned, the control word bit is combined (gated) with the corresponding function on the digital inputs as a logic "or" function.

Status word under VLT standard

The status word is used for informing the leader (e.g. a PC) about the condition of the follower (FCM 300).

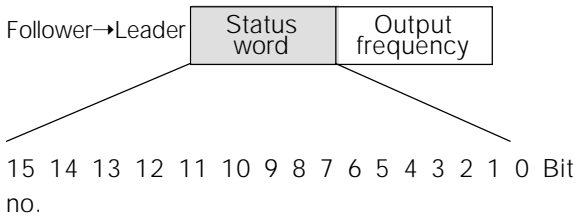

Bit	Bit = 0	Bit = 1
00	Control not ready	Ready
01	FC not ready	Ready
02	Coasting	Enable
03	No fault	Trip
04	Reserved	
05	Reserved	
06	Reserved	
07	No warning	Warning
08	Speed \neq ref.	Speed = ref.
09	Local control	Bus control
10	Out of range	Frequency OK
11	Not running	Running
12		
13	Voltage OK	Above limit
14	Torque OK	Above limit
15	Timer OK	Above limit

Bit 01, FC not ready/ready:

Bit 01 = "0" means that the adjustable frequency drive has tripped.

Bit 01 = "1" means that the adjustable frequency drive is ready.

Bit 02, Coasting/enable:

Bit 02 = "0" means that the control word bit 03 is "0" (Coasting) or that the FCM 300 has tripped.

Bit 02 = "1" means that control word bit 03 is "1" and that the FCM 300 has not tripped.

See the description of other bits under status word for the Profidrive standard.

Bus reference value:

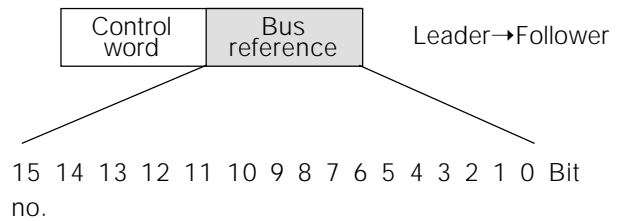

The frequency reference value is transmitted to the adjustable frequency drive in the form of a 16-bit word. The value is transmitted as a whole number (0-32767). 16384 (4000 Hex) corresponds to 100%. (Negative figures are formed by means of 2's complement.)

The bus reference has the following format:

Parameter 203 = "0"

"ref_{MIN}-ref_{MAX}"

0-16384 (4000 Hex) ~ 0-100% ~ ref_{MIN} - ref_{MAX}

Parameter 203 = "1"

-ref_{MAX} - +ref_{MAX}

-16384 (. . . Hex) - +16384 (4000 Hex) ~

-100- +100% ~ -ref_{MAX}- +ref_{MAX}

Actual output frequency

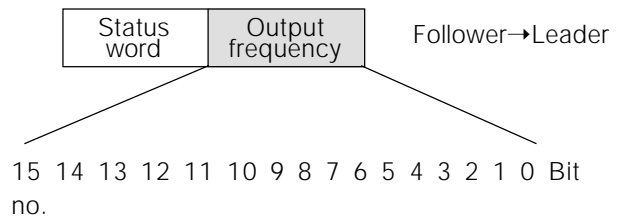

The value of the actual output frequency of the adjustable frequency drive is transmitted in the form of a 16-bit word. The value is transmitted as a whole number (0-32767). 16384 (4000 Hex) corresponds to 100%. (Negative figures are formed by means of 2's complement).

Chapter 16

- List of Warnings and Alarmspage 16-2
- What if the Motor Does Not Start? page 16-2
- Warnings page 16-3
- Warnings Words 1+2 and Alarm Word .page 16-5

■ List of Warnings and Alarms

The table gives the different warnings and alarms and indicates whether the fault locks the FCM 300. After Trip locked, the mains supply must be cut and the fault must be corrected. Reconnect the mains supply and reset the FCM 300 before being ready.

Wherever a X is placed under both Warning and Alarm, this can mean that a warning precedes the alarm. It can also mean that it is possible to program whether a given fault is to result in a warning or an alarm. After a trip, alarm and warning will flash, but if the fault is removed, only alarm will flash. After a reset, the FCM 300 will be ready to start operation again.

No.	Description	Warning	Trip Alarm	Trip locked
2	Live zero fault (LIVE ZERO ERROR)	X	X	
4	Phase loss (MAINS PHASE LOSS)	X	X	X
5	Voltage warning high (DC LINK VOLTAGE HIGH)	X		
6	Voltage warning low (DC LINK VOLTAGE LOW)	X		
7	Overvoltage (DC LINK OVERVOLT)		X	X
8	Undervoltage (DC LINK UNDERVOLT)		X	
9	Inverter overload (INVERTER TIME)	X	X	
11	Motor thermistor (MOTOR THERMISTOR)		X	
12	Current limit (CURRENT LIMIT)	X		
13	Overcurrent (OVERCURRENT)		X	X
14	Earth fault (EARTH FAULT)		X	X
15	Supply fault (SWITCH MODE FAULT)		X	X
16	Short-circuit (CURR.SHORT CIRCUIT)		X	X
17	Standard bus timeout (STD BUS TIMEOUT)	X	X	
18	HPFB bus timeout (HPFB TIMEOUT)	X	X	
33	Out of frequency range (OUT FREQ RNG/ROT LIM)	X		
34	HPFB error (HPFB ALARM)	X	X	
35	Inrush fault (INRUSH FAULT)		X	X
36	Overtemperature (OVERTEMPERATURE)	X	X	
37	Internal error (INTERNAL ERROR)		X	X

■ What if the Motor Does Not Start?

- Make sure no parameters have been changed from factory settings. Use the Local Control Panel (LCP) or serial port to reset to factory settings.
- Check the LCP or Local Operation Pad (LOP) to make sure the (STOP) command has not been pushed. If this is the case, the 4th line of the LCP flashes. Push the (START) button on the LCP or LOP to restart the unit.
- Check the Light Emitting Diodes (LEDs) visible through a hole in the inside isolation cover (see drawing page 6-6), follow the table below.



Warning:

Extreme care must be taken when operating the unit with open lid.

Green LED 302	Yellow LED 301	Red LED 300	Action
OFF	OFF	OFF	Apply power
ON	OFF	OFF	Apply start and reference signals , (see drawing on page 6-6)
ON	OFF	ON	Apply and remove reset signal according to the drawing on page 6-6.
ON	ON	ON	Switch off power until all LED's have turned off
ON	Flashing slowly	OFF	Local stop or Local mode selected. Push Local start and select remote

■ Warnings

The display flashes between normal state and warning. A warning comes up on the first and second line of the display. See examples below:

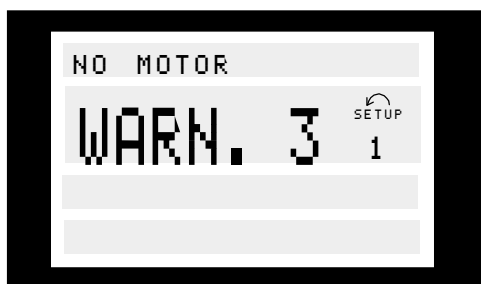
■ Alarm messages

The alarm comes up in the 2. and 3. line of the display, see example below:

WARNING/ALARM 2
Live zero fault (LIVE ZERO ERROR):

The current signal on terminal 1 is less than 50% of the value set in parameter 336 *Terminal 1, min. scaling*.

WARNING/ALARM 4
Phase loss (MAINS PHASE LOSS):

Phase missing on the supply side.
Check the supply voltage to the FCM 300.

WARNING 5
Voltage warning high
(DC LINK VOLTAGE HIGH):

The intermediate circuit voltage (DC) is higher than the overvoltage limit of the control system, see table on this page. The FCM 300 is still active.

WARNING 6
Voltage warning low (DC LINK VOLTAGE LOW):

The intermediate circuit voltage (DC) is below the undervoltage limit of the control system, see table below. The FCM 300 is still active.

ALARM 7
Overvoltage (DC LINK OVERVOLT):

If the intermediate circuit voltage (DC) exceeds the inverter overvoltage limit (see table), the FCM 300 will trip. Furthermore, the voltage will be stated in the display.

ALARM 8
Undervoltage (DC LINK UNDERVOLT):

If the intermediate circuit voltage (DC) drops below the inverter lower voltage limit (see table on this page), the FCM 300 will trip after 3 - 28 sec., depending on unit. Furthermore, the voltage will be stated in the display. Check whether the supply voltage matches the FCM 300, see technical data.

WARNING/ALARM 9
Inverter overload (INVERTER TIME):

The electronic, thermal inverter protection reports that the FCM 300 is about to cut out because of an overload (too high current for too long). The counter for electronic, thermal inverter protection gives a warning at 95% and trips at 100%, while giving an alarm. The FCM 300 cannot be reset until the counter is below 90%.

Trip/Alarm/warning limits:

FCM 300 Series	3 x 380 - 480 V [VDC]
Undervoltage	410
Voltage warning low	440
Voltage warning high	760
Overvoltage	760*

* 760V in 5 sec. or 800V immediately.

The voltages stated are the intermediate circuit voltage of the FCM 300.

Warnings and alarms, cont.**ALARM 11****Motor thermistor (MOTOR THERMISTOR):**

If a thermistor is mounted and parameter 128 is set to *Enable* [1], the FCM 300 will trip if the motor gets too hot.

WARNING 12**Current limit (CURRENT LIMIT):**

The current is higher than the value in parameter 221 (in motor operation).

ALARM 13**Overcurrent (OVERCURRENT):**

The inverter peak current limit (approx. 230% of the rated current) has been exceeded. The FCM 300 will trip, while giving an alarm.

Turn off the FCM 300 and check whether the motor shaft can be turned.

ALARM: 14**Earth fault (EARTH FAULT):**

There is a discharge from the output phases to ground, either between the inverter and the motor or in the motor itself.

ALARM: 15**Supply fault (SWITCH MODE FAULT):**

Fault in the switch mode power supply (internal 24 V supply).

Contact your Danfoss supplier.

ALARM: 16**Short-circuiting (CURR.SHORT CIRCUIT):**

There is short-circuiting on the motor terminals or in the motor itself.

Contact your Danfoss supplier.

NOTE!

If shock loads occur this alarm may appear.

WARNING/ALARM 17**Standard bus timeout (STD BUSTIMEOUT)**

There is no communication to the FCM 300.

The warning will only be active when parameter 514 has been set to another value than *OFF*.

If parameter 514 has been set to *stop and trip*, it will first give a warning and then ramp down until it trips, while giving an alarm.

Parameter 513 *Bus time interval* could possibly be increased.

WARNING/ALARM 18**HPFB bus timeout (HPFB BUS TIMEOUT)**

There is no communication with the FCM 300.

The warning will only be active when parameter 804 has been set to another value than *OFF*.

If parameter 804 has been set to *Stop and trip*, it will first give a warning and then ramp down until it trips, while giving an alarm.

Parameter 803 *Bus time out* could possibly be increased.

WARNING 33**Out of frequency range:**

This warning is active if the output frequency has reached parameter 201 *Output frequency low limit* or parameter 202 *Output frequency high limit*.

WARNING/ALARM 34**HPFB error (HPFB ALARM):**

The profibus communication is not working correctly.

ALARM 35**Inrush fault (INRUSH FAULT):**

This warning occurs when the AC Line has been cycled too many times within 1 minute.

WARNING/ALARM 36**Overtemperature (OVERTEMPERATURE):**

A warning occurs at 78°C/172°F and the FCM 300 trips at 90°C/194°F. The unit can be reset when the temperature is below 70°C/158°F.

ALARM: 37**Internal error (INTERNAL ERROR):**

An error has occurred in the system. Contact your Danfoss supplier.

■ Warning words 1 + 2 and Alarm word

Warning words 1 + 2 and alarm word are shown on the display in Hex format. If there are more than one warning or alarm, a sum of all warnings or alarms will be shown.

Warning words 1 + 2 and alarm word can also be displayed using the serial bus in parameter 540, 541 and 538.

Bit (Hex)	Warning word 1
00000008	HPFB timeout
00000010	Standard bus timeout
00000040	Current limit
00000200	Inverter overload
00001000	Voltage warning low
00002000	Voltage warning high
00004000	Phase loss
00010000	Live zero error warning
00400000	Output freq. limit warning
00800000	HPFB error
40000000	24 V supply warning
80000000	Inverter temp. high

Bit (Hex)	Warning word 2
01	Ramping
04	Start clockwise/ counterclockwise
08	Slow down
10	Catch-up
8000	Frequency limit

Bit (Hex)	Alarm word
00000002	Trip lock
00000040	HPFB timeout
00000080	Standard bus timeout
00000100	Short circuit
00000200	24 V supply fault
00000400	Earth ground fault
00000800	Overcurrent
00004000	Motor thermistor
00008000	Inverter overload
00010000	Undervoltage
00020000	Overvoltage
00040000	Phase loss
00080000	Live zero error
00100000	Overtemperature
02000000	HPFB error
08000000	Inrush fault
10000000	Internal error

Chapter 17

- CE Labeling page 17-2
- The Machinery Directive (89/392/EEC) . page 17-2
- The Low-Voltage Directive /73/23/EEC) page 17-2
- The EMC Directive (89/336/EEC) page 17-2
- Compliance with EMC Directive (89/336/EEC) page 17-2
- What is Covered? page 17-2
- Danfoss VLT DriveMotor & CE Labeling . page 17-3
- Galvanic Isolation (PELV) page 17-3
- Ground Leakage Current page 17-4
- Acoustic Noise page 17-4
- Balance page 17-4
- Extreme Running Conditions page 17-4
- EMC Standards page 17-5
- Harsh Environments page 17-6

■ What is CE Labelling?

The purpose of CE labeling is to avoid technical obstacles to trade within EFTA and the EU. The EU has introduced the CE label as a simple way of showing whether a product complies with the relevant EU directives. The CE label says nothing about the specifications or quality of the product. Adjustable frequency drives are regulated by three EU directives:

■ The Machinery directive (89/392/EEC)

All machines with critical moving parts are covered by the machinery directive, which came into force on 1 January 1995. Since an adjustable frequency drive is largely electrical, and the motor always will be placed in connection with other machines, it does not fall under the machinery directive. However, if a FCM 300 is supplied for use in a machine, we provide information on safety aspects relating to the FCM 300. We do this by means of a manufacturer's declaration.

■ The Low-voltage Directive (73/23/EEC)

Adjustable frequency drives must be CE labelled in accordance with the low-voltage directive. The directive applies to all electrical equipment and appliances used in the voltage range of 50-1000 V AC and 75-1500 V DC.

■ The EMC Directive (89/336/EEC)

EMC is short for electromagnetic compatibility. The presence of electromagnetic compatibility means that the mutual interference between different components/appliances is so small that the functioning of the appliances is not affected. The EMC directive came into force on 1 January 1996. The directive distinguishes between components, appliances, systems and installations.

■ Compliance with EMC Directive 89/336/EEC

In the great majority of cases, the VLT® DriveMotor is used by professionals of the trade as a complex component forming part of a larger appliance, system or installation. It must be noted that the responsibility for the final EMC properties of the appliance, system or installation rests with the installer. As an aid to the installer, Danfoss has

prepared EMC installation guidelines for the Power Drive System. The standards and test levels stated for Power Drive Systems are complied with, provided the right EMC-correct instructions for installation have been followed, see electrical installation.

■ What is Covered?

The EU "Guidelines on the Application of Council Directive 89/336/EEC" outline three typical situations of using a FCM 300. For each of these situations, explanations are offered as to whether the situation in question is covered by the EMC directive and must be CE labeled.

1. The FCM 300 is sold directly to the end-consumer. The FCM 300 is for example sold to a DIY (Do-it-yourself) market. The end-consumer is a layman. He installs the FCM 300 himself for use with a hobby machine, a kitchen appliance, etc. For such applications, the FCM 300 must be CE labeled in accordance with the EMC directive.
2. The FCM 300 is sold for installation in a plant. The plant is built up by professionals of the trade. It could be a production plant or a heating/ventilation plant designed and installed by professionals of the trade. Neither the FCM 300 nor the finished plant has to be CE labeled under the EMC directive. However, the unit must comply with the basic EMC requirements of the directive. The installer can ensure this by using components, appliances and systems that are CE labelled under the EMC directive.
3. The FCM 300 is sold as part of a complete system. The system is being marketed as complete. It could be e.g. an air-conditioning system. The complete system must be CE labeled in accordance with the EMC directive. The manufacturer who supplies the system can ensure CE labeling under the EMC directive either by using CE labeled components or by testing the EMC of the system. If he chooses to use only CE labeled components, he does not have to test the entire system.

■ **Danfoss FCM 300 Series Motor and CE Labeling**

CE labeling is a positive feature when used for its original purpose, i.e. to facilitate trade within the EU and EFTA.

However, CE labeling may cover many different specifications. This means that it has to be checked what a given CE label specifically covers.

The specifications covered can in fact be widely different. That is why a CE label can give the installer a false feeling of security when using a FCM 300 as a component in a system or an appliance.

We CE label our VLT® DriveMotors in accordance with the low-voltage directive. This means that as long as the FCM 300 is installed correctly, we guarantee that it complies with the low-voltage directive. We issue a declaration of conformity that confirms our CE labeling in accordance with the low-voltage directive.

The CE label also applies to the EMC directive, on condition that the instructions given in the Operating Instructions for EMC-correct installation and filtering have been followed. On this basis, a declaration of conformity in accordance with the EMC directive is issued.

We offer the filters that can be seen from the specifications and gladly provide other types of assistance that can help you obtain the best EMC result.

■ **Galvanic Isolation (PELV)**

PELV offers protection by way of extra low voltage. Protection against electric shock is considered to be ensured when all connected devices are of the PELV type and the installation is made as described in local/national regulations on PELV supplies.

In FCM 300 Series all control terminals are supplied from or in connection with extra low voltage (PELV).

Galvanic (ensured) isolation is obtained by fulfilling requirements concerning higher isolation and by providing the relevant creepage/clearance distances. These requirements are described in the EN 50178 standard.

The components that make up the electrical isolation, as described below, also comply with the requirements concerning higher isolation and the relevant test as described in EN 50178.

The galvanic isolation can be shown in three locations (see drawing below), namely:

1. Power supply (SMPS) incl. signal isolation of U_{DC} , indicating the intermediate current voltage.
2. Gate drive that runs the IGBTs (opto-couplers).
3. Current transducers (opto-couplers).

Galvanic isolation

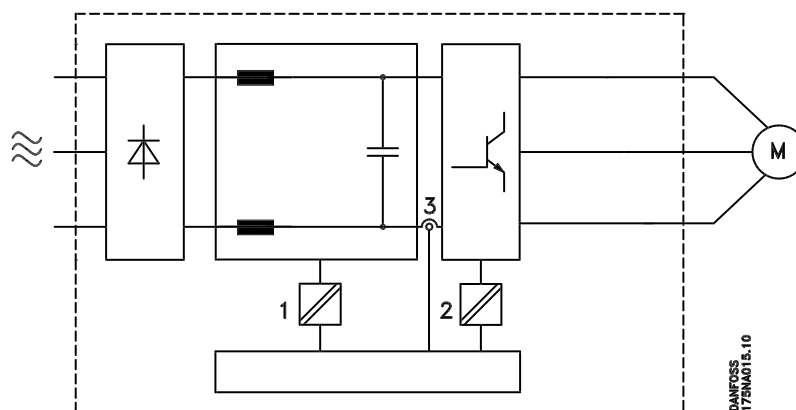

■ Ground Leakage Current

Ground leakage current is primarily caused by the capacitance between motor phases and the motor frame. The RFI filter contributes additional leakage current, as the filter circuit is connected to ground through capacitors.

The amount of the leakage current to the ground depends on the following factors, in order of priority:

1. Switching frequency
2. Motor grounded on site or not

The leakage current is of importance to safety during handling/operation of the adjustable frequency drive if (by mistake) the adjustable frequency drive has not been grounded.

NOTE!

Since the leakage current is > 3.5 mA (approx. 4-20 mA), reinforced grounding must be established (see Quick Guide MG.03.A1.02), which is required if EN 50178 is to be complied with. Never use ELCB relays that are not suitable for DC fault currents (type A).

If ELCB relays are used, they must be:

- Suitable for protecting equipment with a direct current content (DC) in the fault current (3-phase bridge rectifier)
- Suitable for power-up with short charging current to ground
- Suitable for a high leakage current.

■ Acoustic Noise

Below are the typical values measured at a distance of 3 ft (im). from the unit at full load:

	2 pole	4 pole
FCM 305		54 dB(A)
FCM 311		58 dB(A)
FCM 315		59 dB(A)
FCM 322		58 dB(A)
FCM 330		61 dB(A)
FCM 340	62 dB(A)	63 dB(A)
FCM 355	64 dB(A)	60 dB(A)
FCM 375		61 dB(A)

■ Balance

The FCM 300 is balanced to class R according to ISO2373 (reduced balance). For critical applications especially at high speed (>4000 RPM) special balance (class S) might be required.

■ Extreme Running Conditions
Motor-generated overvoltage

The voltage in the intermediate circuit is increased when the motor acts as a generator. This occurs in two cases:

1. The load drives the motor (at constant output frequency from the adjustable frequency drive), i.e. the load generates energy.
2. During deceleration ("ramp-down") if the moment of inertia is high, the load is low and the ramp-down time is too short for the energy to be dissipated as a loss in the VLT adjustable frequency drive, the motor and the installation.

The control unit attempts to correct the ramp if possible.

The inverter turns off to protect the transistors and the intermediate circuit capacitors when a certain voltage level is reached.

AC Line drop-out

During an AC Line drop-out, FCM 300 Series continues until the intermediate circuit voltage drops below the minimum stop level, which is typically 15% below FCM 300 Series's lowest rated supply voltage.

The time before the inverter stops depends on the mains voltage before the drop-out and on the motor load.

Static overload

When FCM 300 Series is overloaded (the current limit in parameter 221 has been reached), the controls will reduce the output frequency in an attempt to reduce the load.

If the overload is excessive, a current may occur that makes the FCM 300 cut out after approx. 1.5 sec.

■ EMC Standards
NOTE!

- All EMC specifications are stated with factory settings.
- Maximum 4 kHz switching frequency.
- Shielded data/control cables must be used for surge protection.
- The FCM 300 must be connected to ground in order to comply.
- Maximum/minimum line impedance
 $Z_{\max} = 0.24 + j0.15 \text{ ohm}$; $Z_{\min} = 0 + j0 \text{ ohm}$.
 (EN 61800-3 commutation notches)

Generic standards

The generic standards are stated in the EMC directive (89/336/EEC).

The FCM 300 complies with:

EN 50081-1¹⁾, EN 50082-1.

Residential, commercial and light industrial environment.

EN 50081-2, EN 50082-2.

Industrial environment.

¹⁾Emission levels stated by EN 50081-1 are only fulfilled by FCM 300 with class B-1 optional filter.

Furthermore the FCM 300 complies with:

DIN VDE 0160/1990 ²⁾

²⁾'Protection against overvoltage 7.3.1. class1'

Product standards

The product standards are stated in EN 61800-3 (IEC 1800-3).

The FCM 300 complies with:

EN 61800-3, unrestricted distribution³⁾.

EN 61800-3, restricted distribution.

³⁾ Emission levels stated by EN 61800-3 unrestricted distribution are only fulfilled by FCM 300 with class B-1 filter.

Basic standards, emissions

- *EN 55011:* Limits and methods of measuring radio disturbance characteristics of industrial, scientific and medical (ISM) radio-frequency equipment.

- *EN 55022:* Limits and methods of measuring radio disturbance characteristics of information technology equipment.

- *EN 61000-3-2:* Limits for harmonic current emissions (equipment input current $\leq 16 \text{ A}$)

- *EN 61000-3-4:* Limits for harmonic current emissions (equipment input current $\geq 16 \text{ A}$)

Basic standards, immunity

- *EN 61000-2-4 (IEC 1000-2-4):*

Compatibility levels

Simulation of voltage and frequency fluctuations, harmonics and commutation notches on the power line.

- *EN 61000-4-2 (IEC 1000-4-2):*

Electrostatic discharge (ESD)

Simulation of electrostatic discharge.

- *EN 61000-4-4 (IEC 1000-4-4):*

Fast transients, burst 5/ 50 nS

Simulation of transients caused by switching of contactors, relays or similar devices.

- *EN 61000-4-5 (IEC 1000-4-5):*

Surges 1.2/ 50 μS .

Simulation of transients caused by e.g. lightning that strikes near an installation.

- *EN 61000-4-6: (IEC 1000-4-6):*

Radio-frequency electromagnetic field.

Amplitude modulated.

Simulation of interference caused by radio transmission equipment.

- *ENV 50140:*

Radio-frequency electromagnetic field. Pulse modulated.

Simulation of interference caused by GSM mobile phones.

General aspects of EMC emissions

For high frequency shielding, shielded cables used for Profibus, standard bus, control cables and signal interface must in general be connected to the enclosure at both ends.

General aspects of EMC immunity

If there are problems with low frequency interference (ground loops), shielded cable used for Profibus, standard bus, control cables and signal interface can be left open at one end.

■ Harsh Environments

In common with all electronic equipment, a VLT adjustable frequency drive contains a large number of mechanical and electronic components, all of which are vulnerable to environmental effects to some extent.



The FCM 300 should not therefore be installed in environments with airborne liquids, particles or gases capable of affecting and damaging the electronic components. Failure to take the necessary protective measures increases the risk of stoppages, thus reducing the life of the unit.

Liquids can be carried through the air and condense in the FCM 300. In addition to this, liquids may cause corrosion of components and metal parts.

Steam, oil and salt water may cause corrosion of components and metal parts.

In such environments, equipment with enclosure rating \geq IP 54 is recommended.

In environments with high temperatures and humidity, corrosive gases such as sulphur, nitrogen and chlorine compounds will cause chemical processes on the FCM 300 components. Such chemical reactions will rapidly affect and damage the electronic components.

NOTE!

Mounting FCM 300 units in harsh environments will increase the risk of stoppages and furthermore considerably reduce the life of the converter.

Before the installation of the FCM 300, the ambient air should be checked for liquids, particles and gases. This may be done by observing existing installations in this environment. Typical indicators of harmful airborne liquids are water or oil on metal parts, or corrosion of metal parts.

Excessive dust particle levels are often found on installation cabinets and existing electrical installations. One indicator of aggressive airborne gases is blackening of copper rails and cable ends on existing installations.

Chapter 18

- Derating page 18-2
- Derating for Ambient Temperature and
for running at low speed page 18-2
- Derating for Air Pressure page 18-2
- Derating for High Switching Frequency page 18-3
- Vibration and Shock page 18-3
- Air Humidity page 18-3
- Efficiency page 18-3
- Harmonics page 18-4
- Power Factor page 18-4

Derating

The FCM 300 Series is thermally protected. At high temperatures the switching frequency will be automatically reduced down to 2 kHz. If the temperature still climbs, the motor will trip.

Derating for ambient temperature

The ambient temperature ($T_{AMB,MAX}$) is the maximum temperature allowed. The average ($T_{AMB,AVG}$) measured over 24 hours must be at least 5°C lower.

If FCM 300 Series is operated at temperatures above 40 °C, a derating of the continuous output current is necessary.

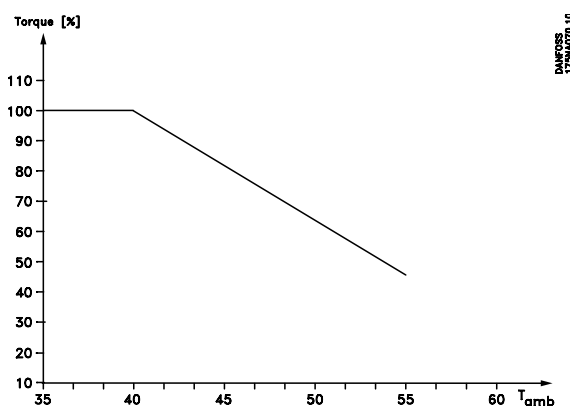

Derating for running at low speed

When a centrifugal pump or a fan is controlled by a FC motor, it is not necessary to reduce the output at low speed because the load characteristic of the centrifugal pumps/fans, automatically ensures the necessary reduction.

FC motors running constant load torque applications continuously at low speed must be derated (see diagram) or an independent fan must be used (cooling option 6).

Nominal torque (100%) can be yielded up to 15 min and at a duty cycle up to 25% at low speed.

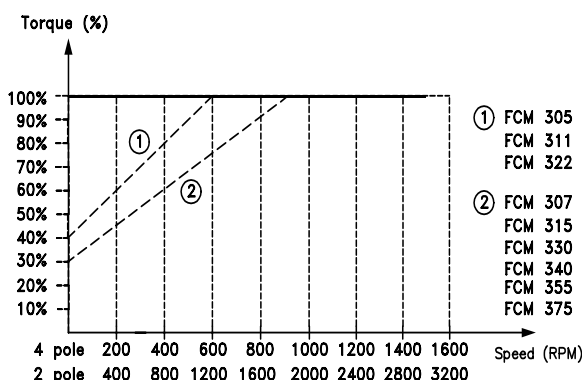

175NA012.14

Derating for Air Pressure

Below (3300 ft.) altitude no derating is necessary.

Above (3300 ft.) the ambient temperature (T_{AMB}) or max. output current ($I_{VLT,MAX}$) must be derated in accordance with the following diagram:

- Derating of output current versus altitude at $T_{AMB} = \text{max. } 40^{\circ}\text{C}/104^{\circ}\text{F}$
- Derating of max. T_{AMB} versus altitude at 100% output current.

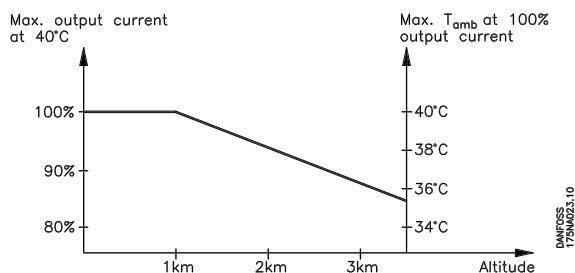

■ Derating for High Switching Frequency

The FCM 300 Series motor can use two different PWM schemes, SFAVM and 60° AVM. Factory setting is SFAVM. The PWM scheme can be changed in parameter 446. Below 25 Hz motor speed the FCM 300 Series motor automatically change to SFAVM.

Factory setting of the switching frequency is 4000 Hz. It can be changed between 2 and 14 kHz in parameter 411.

A higher switching frequency leads to a quieter running unit but higher losses in the electronics of the FCM 300 and makes an appropriate derating necessary.

■ Vibration and Shock

FCM 300 Series has been tested according to a procedure based on the following standards:

IEC 68-2-6:	Vibration (sinusoidal) - 1970
IEC 68-2-34:	Random vibration broad-band - general requirements
IEC 68-2-35:	Random vibration broad-band - high reproducibility
IEC 68-2-36:	Random vibration broad-band - medium reproducibility

FCM 300 Series complies with requirements that correspond to conditions in the standards mentioned above.

■ Air Humidity

FCM 300 Series has been designed to meet the IEC 68-2-3 standard, EN 50178 item 9.4.2.2/DIN 40040, class E, at 40°C/104°F.

■ Efficiency

η % (3000 rpm)

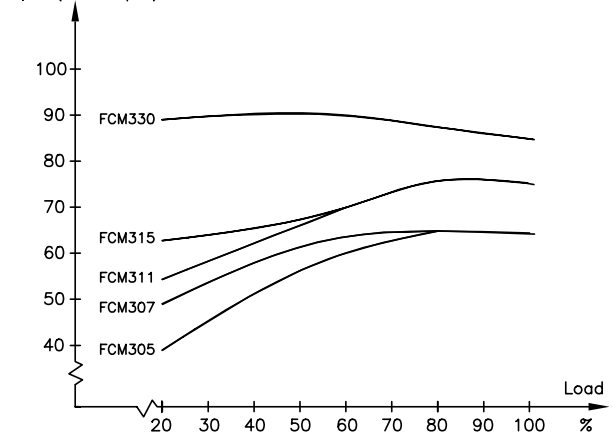

175NA064.10

2 pole

η % (1500 rpm)

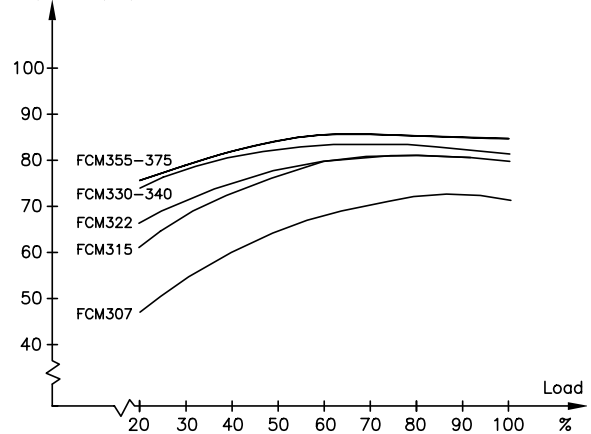

175NA016.13

4 pole

■ **AC Line supply Interference/Harmonics**

A FCM 300 draws a non-sinusoidal current from the AC Line which increases the input current I_{RMS} . A non-sinusoidal current can be transformed by means of a Fourier analysis and split up into sine wave currents with different frequencies, i.e. different harmonic currents I_N with 60 Hz as the basic frequency:

Harmonic currents	I_1	I_5	I_7	I_{11}
Hz	60 Hz	300 Hz	420 Hz	660 Hz
I_n/I_1 [%]	100%	44%	29%	8%

The harmonics do not affect the power consumption directly, but increase the heat losses in the installation (transformer, cables). Consequently, in plants with a rather high percentage of non-linear loads, it is important to maintain harmonic currents at a low level to avoid overload of the transformer and high temperature in the cables.

Some of the harmonic currents might disturb communication equipment connected to the same transformer or cause resonance in connection with power-factor correction equipment.

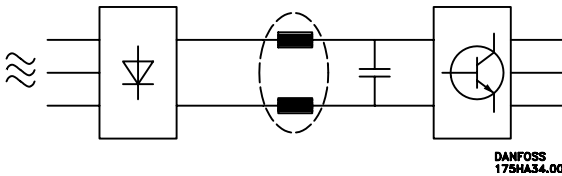

To ensure low, harmonic currents, FCM 300 has intermediate circuit coils as standard..

THD (current) $\leq 54\%$

The voltage distortion on the AC Line supply depends on the size of the harmonic currents multiplied by the supply impedance for the frequency in question.

The total voltage distortion THD is calculated on the basis of the individual voltage harmonics using the following formula:

$$THD = \frac{U_1}{\sqrt{U_2^2 + \dots + U_N^2}} \quad (\%)$$

■ **Power Factor**

The power factor is the relation between I_1 and I_{RMS} .

The power factor for 3-phase control

$$= \frac{\sqrt{3} \times U \times I_1 \times \cos \varphi_1}{\sqrt{3} \times U \times I_{RMS}}$$

$$\text{Power factor} = \frac{I_1 \times \cos \varphi_1}{I_{RMS}} = \frac{I_1}{I_{RMS}} \approx 0.9 \text{ since } \cos \varphi = 1$$

The power factor indicates the extent to which the FCM 300 imposes a load on the AC Line supply.

The lower the power factor, the higher the I_{RMS} for the same HP/kW performance.

In addition, a high power factor indicates that the different harmonic currents are low.

$$I_{RMS} = \sqrt{I_1^2 + I_5^2 + I_7^2 + \dots + I_n^2}$$

Chapter 19

- Standard Parameter Settingspage 19-2
- Special Parameter Settings
for HVAC products page 19-5
- Special Parameter Settings
for Industrial products page 19-5



FCM 300 Series

Parameters

■ Standard Parameter Setting

Parameters for programming, controlling, and monitoring the FCM 300 via serial communication or PC.

	Function	Range/number of settings/value	Factory setting	Parameter No.
Operation and display	Language	6	English	Parameter 001
	Local/remote control	2	Remote control	Parameter 002
	Local reference		000.000	Parameter 003
	Active Setup	4	Setup 1	Parameter 004
	Programming Setup	4	Active setup	Parameter 005
	Copying of Setups	4	No copying	Parameter 006
	LCP copy	4	No copying	Parameter 007
	Display scaling of motor frequency		100	Parameter 008
	Display line 2	24	Frequency [Hz]	Parameter 009
	Display line 1.1		Reference [%]	Parameter 010
	Display line 1.2		Motor current [A]	Parameter 011
	Display line 1.3		Power [kW]	Parameter 012
	Local control/configuration	5	LCP digital control/par. 100	Parameter 013
	Local stop	2	Possible	Parameter 014
	Local jog	2	Not possible	Parameter 015
	Local reversing	2	Not possible	Parameter 016
	Local reset of trip	2	Possible	Parameter 017
	Lock for data change	2	Not locked	Parameter 018
	Load and motor	Operating state at power up, local c.	3	Forced stop, use saved ref.
Configuration		2	Speed, open loop mode	Parameter 100
Torque characteristics		4	Constant torque	Parameter 101
Motor power		XX.XX kW - dep. on unit		Parameter 102
Motor voltage		XX.XX V - dep. on unit		Parameter 103
Motor frequency		XX.X Hz - dep. on unit		Parameter 104
Motor current		XX.XX A - dep. on unit		Parameter 105
Rated motor speed		XX rpm - dep. on unit		Parameter 106
DC braking time		0.0 (off) - 60.0 sec.	10.0 sec.	Parameter 126
DC brake cut-in frequency		0.0 Hz - f_{MAX}	0.0 Hz	Parameter 127
Motor thermal protection		2	Disable	Parameter 128
DC braking voltage		0 - 100 %	0 %	Parameter 132
Start voltage		0.00 - 100.00 V	Motor dependent	Parameter 133
Start compensation		0.0 - 300.0 %	100.0 %	Parameter 134
U/f ratio		0.00 - 20.00 V/Hz	Motor dependent	Parameter 135
Slip compensation		-500.0 - +500.0 %	100.0 %	Parameter 136
DC holding voltage		0 - 100 %	0 %	Parameter 137
Brake cut out frequency		0.5 - 132 Hz	3.0 Hz	Parameter 138
Brake cut in frequency		0.5 - 132 Hz	3.0 Hz	Parameter 139
References and limits		Rotation direction	3	Only clockwise 0 - 132 Hz
	Min. output frequency (f_{MIN})	0.0 Hz - f_{MAX}	0.0 Hz	Parameter 201
	Max. output frequency (f_{MAX})	f_{MIN} - f_{RANGE}	f_{RANGE} (132 Hz)	Parameter 202
	Reference/feedback range	Min. - max./-max.- +max.	Min. - Max.	Parameter 203
	Minimum reference	-100,000.000 - Ref_{MAX}	0.000	Parameter 204
	Maximum reference	Ref_{MIN} - 100,000.000	50.000	Parameter 205
	Ramp-up time 1	0.05 - 3600.00 sec.	3.00 sec.	Parameter 207
	Ramp-down time 1	0.05 - 3600.00 sec.	3.00 sec.	Parameter 208
	Jog ramp time	0.05 - 3600.00 sec.	3.00 sec.	Parameter 211
	Quick stop ramp-down time	0.05 - 3600.00 sec.	3.00 sec.	Parameter 212
Jog frequency	0 Hz - f_{MAX}	10.0 Hz	Parameter 213	
Reference function	2	Sum	Parameter 214	

■ Standard Parameter Settings

	Function	Range/number of settings	Factory setting	Parameter No.
	Preset reference 1	-100.00 % - +100.00 %	0.00 %	Parameter 215
	Preset reference 2	-100.00 % - +100.00 %	0.00 %	Parameter 216
	Catch up/slow down value	0.00 - 100.00 %	0.00 %	Parameter 219
	Current limit for motor mode	Min.- max. limit in % of I _{RATED}	Max. limit	Parameter 221
	Frequency bypass, bandwidth	0 (off) - 100 %	0 %	Parameter 229
	Frequency bypass 1	0.0 - 132 Hz	0.0 Hz	Parameter 230
	Frequency bypass 2	0.0 - 132 Hz	0.0 Hz	Parameter 231
	Time out	1 -99 sec.	10 sec.	Parameter 317
	Function after time out	Off/Stop and trip	Off	Parameter 318
	Pulse reference/feedback, max. freq.	100 - 70000 Hz	5000 Hz	Parameter 327
Inputs and Outputs	Terminal 1, analog input current	3	No operation	Parameter 331
	Terminal 2, digital input	25	Reference	Parameter 332
	Terminal 3, digital input	25	Reset	Parameter 333
	Terminal 4, digital input	24	Start	Parameter 334
	Terminal 5, digital input	23	Jog	Parameter 335
	Terminal 1, min. scaling	0.0 - 20.0 mA	0.0 mA	Parameter 336
	Terminal 1, max. scaling	0.0 - 20.0 mA	20.0 mA	Parameter 337
	Terminal 2, min. scaling	0.0 - 10.0 V	0.0 V	Parameter 338
	Terminal 2, max. scaling	0.0 - 10.0 V	10.0 V	Parameter 339
		Output functions	21	No operation
	Brake function	Off/AC braking	Off	Parameter 400
	Reset function	11	Manual reset	Parameter 405
	Switching frequency	1.5 - 14.0 kHz	Unit dependent	Parameter 411
	Variable switching frequency	3	Temp. dep. sw. freq.	Parameter 412
	Overmodulation function	Off/On	On	Parameter 413
	Minimum feedback	-100000 - FB _{HIGH}	0	Parameter 414
	Maximum feedback	FB _{LOW} - 100,000	1500	Parameter 415
	Reference/feedback unit	42	%	Parameter 416
Special functions	Process PID normal/inverse ctrl.	Normal/inverse	Normal	Parameter 437
	Process PID anti windup	Disable/Enable	Enable	Parameter 438
	Process PID start frequency	f _{MIN} - f _{MAX}	f _{MIN}	Parameter 439
	Process PID proportional gain	0.00 (off) - 10.00	0.01	Parameter 440
	Process PID integral time	0.01 - 9999 sec. (off)	9999 sec.	Parameter 441
	Process PID differentiation time	0.00 (off) - 10.00 sec.	0.00 sec.	Parameter 442
	Process PID different. gain limit	5 -50	5	Parameter 443
	Process PID lowpass filter time	0.1 - 10.00 sec.	0.1 sec.	Parameter 444
	Flying start	4	Disable	Parameter 445
	Switching pattern	2	SFAVM	Parameter 446
Serial communication	Bus address	1 - 126	1	Parameter 500
	Baudrate	300 - 9600 Baud/6	9600 Baud	Parameter 501
	Coasting	4	Logic or	Parameter 502
	Quick-stop	4	Logic or	Parameter 503
	DC-brake	4	Logic or	Parameter 504
	Start	4	Logic or	Parameter 505
	Reversing	4	Logic or	Parameter 506
	Selection of setup	4	Logic or	Parameter 507
	Selection of speed	4	Logic or	Parameter 508
	Bus jog 1	0.0 - f _{MAX}	10.0 Hz	Parameter 509
	Bus jog 2	0.0 - f _{MAX}	10.0 Hz	Parameter 510
	Telegram profile	Profidrive/FC Drive	FC Drive	Parameter 512
	Bus time interval		1 sec.	Parameter 513
	Bus time interval function	6	Off	Parameter 514



FCM 300 Series

Parameters

■ Standard Parameter Settings

Function	Range/number of settings	Factory setting	Parameter No.
Data read-out: Reference	XXX.X		Parameter 515
Data read-out: Refer. unit	Hz/rpm		Parameter 516
Data read-out: Feedback			Parameter 517
Data read-out: Frequency	Hz		Parameter 518
Data read-out: Frequency x scale	Hz		Parameter 519
Data read-out: Current	A x 100		Parameter 520
Data read-out: Torque	%		Parameter 521
Data read-out: Power	kW		Parameter 522
Data read-out: Power	hp		Parameter 523
Data read-out: Motor voltage	V		Parameter 524
Data read-out: DC link voltage	V		Parameter 525
Data read-out: FC therm.	0 - 100 %		Parameter 527
Data read-out: Digital input			Parameter 528
Data read-out: External reference	-200.0 - +200.0 %		Parameter 533
Data read-out: Status word, binary			Parameter 534
Data read-out: FC temperature	°C		Parameter 537
Data read-out: Alarm word, binary			Parameter 538
Data read-out: Control word, binary			Parameter 539
Data read-out: Warning word, 1			Parameter 540
Data read-out: Warning word, 2			Parameter 541
Data read-out: Terminal 1, analog input	mA X 10		Parameter 542
Data read-out: Terminal 2, analog input	V X 10		Parameter 543
Operating data: Operating hours	0 - 130,000.0 hours		Parameter 600
Operating data: Hours run	0 - 130,000.0 hours		Parameter 601
Operating data: Number of power-up's	0 - 9999		Parameter 603
Operating data: Number of overtemp.	0 - 9999		Parameter 604
Operating data: Number of overvoltages	0 - 9999		Parameter 605
Fault log, read-out: Error code	Index XX - XXX		Parameter 615
Fault log, read-out: Time	Index XX - XXX		Parameter 616
Fault log, read-out: Value	Index XX - XXX		Parameter 617
Reset of hours-run counter	No reset/reset	No reset	Parameter 619
Operation mode	3	Normal function	Parameter 620
Nameplate: FC motor type	Depends on unit		Parameter 621
Nameplate: Software version no.	Depends on unit		Parameter 624
LCP version	Depends on unit		Parameter 625
Nameplate: Database identification no.	Depends on unit		Parameter 626
Nameplate: Application option type			Parameter 628
Nameplate: Communication option type			Parameter 630
BMC software identification			Parameter 632
Motor database identification			Parameter 633
Unit identification for communication			Parameter 634
Software part No.			Parameter 635

Technical functions



FCM 300 Series

■ Special Parameter Settings for HVAC Products

Function	Range/number of settings	HVAC setting	Parameter No.
Operation and Display			
Display line 1.3	HP	Power HP	Parameter 012
Operating state at power up, local		Auto restart	Parameter 019
Load and Motor			
Torque characteristics		Variable torque high	Parameter 101
Slip compensation	-500 - +500%	0%	Parameter 136
References and Limits			
Min. output frequency	0 Hz - f_{MAX}	6.0 Hz	Parameter 201
Min. reference	-100,000.000 - Ref_{MAX}	6.000 Hz	Parameter 204
Max. reference	Ref_{MIN} - 100,000.000	60.000 Hz	Parameter 205
Ramp-up time	0.15 - 3600.00 sec.	60.00 sec.	Parameter 207
Ramp-down time	0.15 - 3600.00 sec.	60.00 sec.	Parameter 208
Jog ramp time	0.15 - 3600.00 sec.	60.00 sec.	Parameter 211
Reference function		External/preset	Parameter 214
Inputs and Outputs			
Term. 1, analogue input current		Reference	Parameter 331
Term. 1, min. scaling	0.0 - 20.0 mA	4.0 mA	Parameter 336
Term. 9, output functions		Motor running	Parameter 340
Special Functions			
Reset function		Automatic reset x 10	Parameter 405
Max. feedback	FB_{LOW} - 100,000.000	100.000	Parameter 415
PID proportional gain	0.00 - 10.00	0.3	Parameter 440
PID integral time	0.01 - 9999 sec.	20 sec.	Parameter 441
Flying start		OK - both directions	Parameter 445
Switching pattern		60° AVM	Parameter 446

■ Special Parameter Settings for Industrial Products

Function	Range/number of settings	Industrial setting	Parameter No.
Operation and Display			
Display line 1.3	HP	Power [HP]	Parameter 012
References and Limits			
Max. reference	Ref_{MIN} - 100,000.000	60.000	Parameter 205
Inputs and Outputs			
Term. 1, analogue input current		Reference	Parameter 331
Term. 1, min. scaling	0.0 - 20.0 mA	4.0 mA	Parameter 336
Term. 9, output functions		Motor running	Parameter 340
Special Functions			
Max. feedback	FB_{LOW} - 100,000.000	100.000	Parameter 415
PID proportional gain	0.00 - 10.00	0.3	Parameter 440
PID integral time	0.01 - 9999 sec.	20 sec.	Parameter 441



FCM 300 Series

Chapter 20

■ Index page 20-2

Index

Index

A

Acoustic noise	17-4
Adapters, PG to NPT	2-2, 4-5, 6-6
Air humidity	18-3
Alarm word	16-5
Alignment	6-2
Axial and radial loads	16-2, 16-3

B

Bearings	6-5
Bolt torques	6-3

C

CE labelling	17-2
Cleaning of the FC motor	6-3
Compliance with EMC directive 89/336/EEC	17-2
Control keys	7-6

D

Databytes	15-4
Parameter bytes	15-4
Process-bytes	15-6
Derating for air pressure	18-2
Derating for ambient temperature	18-2
Derating for high switching frequency	18-3, 18-7
Derating for running at low speed	18-2
Dimensions	3-2
Face mounting - B14, B34 (B3+B14)	3-3
Flange mounting - B5, B35 (B3+B5)	3-3
Foot mounting - B3	3-2
Display line 2	8-4

E

Earth fault	16-4
Earth leakage current	17-4
Efficiency	18-3
EMC directive	17-2
EMC standards	17-5
Extreme running conditions	17-4
Mains drop-out	17-4
Motor-generated overvoltage	17-4
Static overload	17-4

G

Galvanic isolation (PELV)	17-3
---------------------------------	------

H

Handling the FC motor	6-5
-----------------------------	-----

I

Inertia	6-5
Initialisation	14-3
Installation of the FC motor	6-2
Integration of frequency converter and motor	3-2, 5-2, 6-2, 6-3, 6-4, 6-5
Control structures	5-2

L

LEDs	7-5
LED 300-304	6-6
Local control panel	
Control keys	7-6
Display read-out state	7-7
Menu structure	7-11
Local reference	8-3
Low-voltage directive (73/23/EEC)	17-2

M

Machinery directive	17-2
Mains supply interference/harmonics	18-4

O

Ordering	4-5
Output shafts	6-5

P

Parameters	
Active Setup	8-3
Address	13-2
Baudrate	13-2
BMC software identification	14-5
Bus jog 1	13-3
Bus jog 2	13-3
Bus time interval	13-3
Bus time interval function	13-4
Catch up/slow down value	10-5
Coasting	13-2
Configuration	8-6
Copying of Setups	8-4
Current limit for motor mode	10-5
Data read-out: Alarm word	13-7
Data read-out: Control word	13-7
Data read-out: Current	13-5
Data read-out: DC link voltage	13-6
Data read-out: Digital input	13-6
Data read-out: External reference %	13-6
Data read-out: FC therm.	13-6
Data read-out: Feedback	13-4
Data read-out: Frequency	13-4
Data read-out: Inv. temperature	13-7
Data read-out: Motor voltage	13-5
Data read-out: Power, HP	13-5
Data read-out: Power, kW	13-5



FCM 300 Series

Data read-out: Reference %	13-4	Operating data: Operating hours	14-2
Data read-out: Reference unit	13-4	Operating mode (OPERATION MODE)	14-4
Data read-out: Status word, binary	13-6	Operating state at power up, local control	8-8
Data read-out: Terminal 1, analogue input	13-8	Overmodulation function	12-3
Data read-out: Terminal 2, analogue input	13-8	Parameter number (PNU)	15-5
Data read-out: Torque	13-5	Preset reference 1	10-5
Data read-out: Warning word, 1	13-7	Preset reference 2	10-5
Data read-out: Warning word, 2	13-8	Process PID anti windup	12-4
DC brake cut-in frequency	9-3	Process PID diff. gain limit	12-5
DC braking time	9-3	Process PID differentiation time	12-5
DC braking voltage	9-3	Process PID integral time	12-5
DC-brake	13-2	Process PID lowpass filter time	12-6
Display line 1.1	8-5	Process PID proportional gain	12-5
Display line 1.2	8-6	Process PID start frequency	12-4
Display line 1.3	8-6	Programming Setup	8-3
Display line 2	8-4	Quick stop ramp-down time	10-4
Display scaling of motor frequency	8-4	Quick-stop	13-2
Fault log: Error code	14-3	Ramp-down time 1	10-3
Fault log: Time	14-3	Ramp-up time 1	10-3
Fault log: Value	14-4	Rated motor speed	9-3
Flying start	12-6	Reference function	10-4
Frequency bypass 1	10-6	Reference/feedback range	10-2
Frequency bypass, bandwidth	10-6	Reset function	12-2
Function after time out	11-2	Reset of hours-run counter	14-2
Jog frequency	10-4	Reversing	13-2
Jog ramp time	10-4	Rotation direction	10-2
Language	8-2	Selection of Setup	13-2
LCP copy	8-4	Selection of speed	13-2
Local Control/Configuration	8-6	Slip compensation	9-4
Local jog	8-7	Start	13-2
Local reference	8-3	Start compensation	9-4
Local reset of trip	8-7	Start voltage	9-4
Local reversing	8-7	Switching frequency	12-2
Local stop	8-7	Switching pattern	12-6
Local/remote control	8-2	Telegram profile	13-3
Lock for data change	8-8	Terminal 1, analogue input current	11-2
Max. output frequency	10-2	Terminal 1, max. scaling	11-5
Maximum feedback	12-3	Terminal 2, analogue/digital input	11-3
Maximum reference	10-3	Terminal 2, max. scaling	11-6
Min. output frequency	10-2	Terminal 2, min. scaling	11-5
Minimum feedback	12-3	Terminal 3, digital input	11-3
Minimum reference	10-3	Terminal 4, digital input	11-3
Motor current	9-3	Terminal 5, digital input	11-3
Motor database identification	14-5	Terminal 9, output functions	11-6
Motor frequency	9-2	Time out	11-2
Motor power	9-2	Torque characteristics	9-2
Motor voltage	9-2	U/f ratio	9-4
Nameplate: Application option type	14-5	Unit identification for communication	14-5
Nameplate: Communication option type	14-5	Variable switching frequency	12-2
Nameplate: Database identification no.	14-5	PC software for serial communication	15-2
Nameplate: FC type	14-4	Periodic maintenance of motor part	6-3
Nameplate: Software version no.	14-4	PG to NPT adapters	2-2, 4-5, 6-6
Operating data: Hours run	14-2	Power factor	18-4
Operating data: Number of overtemperatures	14-2	Process-bytes	15-6
Operating data: Number of overvoltages	14-2	Product range	4-5
Operating data: Number of power-ups	14-2	Inverter versions	4-5

Mounting versions 4-5

R

RCD 17-4

S

Serial bus 15-3

Start 13-2

T

Technical data

Control card, analogue inputs: 2-3

Control card, digital/pulse and
analogue outputs 2-3

Control card, digital/pulse inputs 2-3

Control card, pulse input: 2-3

Control card, RS 485 serial communication 2-3

Control characteristics 2-3

Externals 2-4

FCM 305-375 for 3 phase, 380-480 V 2-2

Torque characteristics 2-2

Telegram build-up 15-3

Data control byte (BCC) 15-4

Telegram length (LGE) 15-3

VLT address (ADR) 15-4

Telegram communication 15-3

Broadcast 15-3

Control and reply telegrams 15-3

Terminal arrangement 6-6

V

Vibration and shock.....18-3

W

Warning words 16-5

Warnings 16-2

warnings 16-2

